

CW662

TEMPERATURE CONTROLLER
HOT RUNNER SYSTEMS

User Manual
English



<< Stand type

YUDO
Consilience Technology

HEAD OFFICE & FACTORY
1112, Seohae-Ro, Paltan-Myeon, Hwaseong-City, Gyeonggi-Do, 445-915 Korea
Tel. + 82 31 350 2530 (Overseas Sales Team) Fax. + 82 31 354 7446
E-mail. yudo@yudohot.com Web. www.yudo.com

Ver. 2.0 MN CW 662 [15. Mar]

► We reserve the right to change specifications without notice.

CA US

tdv
ISO9001:2008

CE
ISO9001:2008

YUDO



Thank you for using YUDO product.

Please read this manual carefully before you use YUDO product.
You can contact YUDO Headquarters for technical advice.

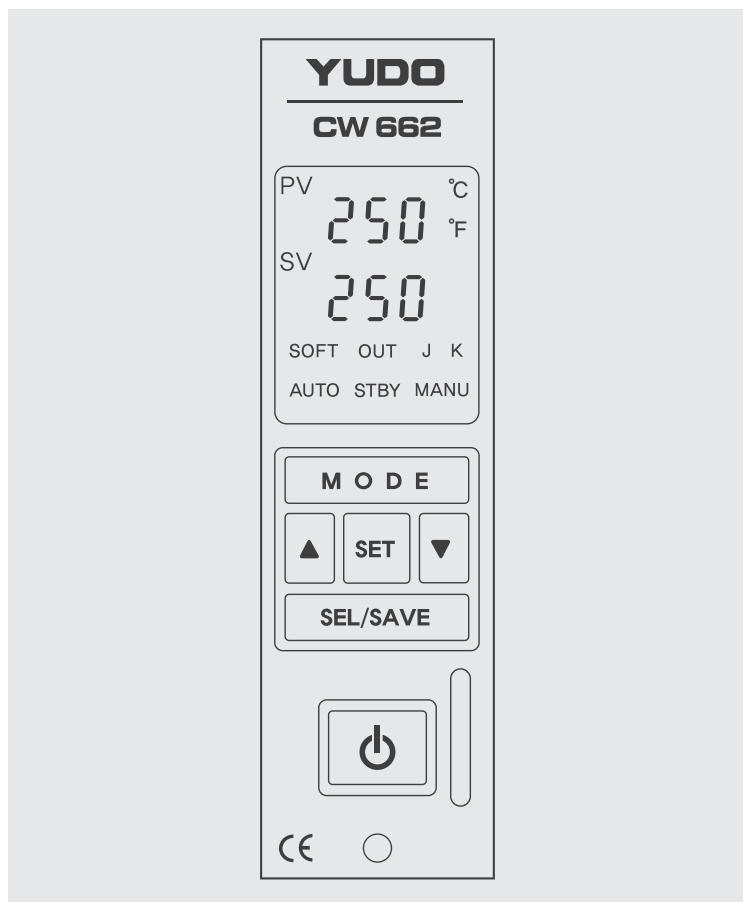

CONTENTS

1. Inspection and Operation	02
1) Product Check	
2) Safety Precautions	
3) Operating Procedure	
2. Structure of Controller	05
3. Name of Components	05
4. Controller Unit Specifications	06
1) Input specifications	
2) Output specifications	
3) System specifications	
4) Environment specifications	
5. Outline of controller and temperature control method	07
1) Outline of Controller	
2) Temperature Control Method	
6. Protective Functions	07
7. Operation Mode	08
1) Operation Mode Selection	
2) Display Change	
8. Menu Setting	09
1) User's Setting Menu (PR-1)	
2) Supplier's Setting Menu (PR-2)	
3) Edit Menu (PR-3)	
9. Reset Function	20
10. Integrated Control Function (Optional)	20
11. Connector and Cable	21
1) How to wire heater and T/C in connectors	
(1) Standard Specifications	
(2) Options	
12. Diagram for Unit and Structure	22
13. Electric Wiring Diagram	23
1) 220V (3 Phases 3 Lines Type)	
2) 380V (3 Phases 4 Lines Type)	
3) 220V (1 Phases 2 Lines Type)	
14. Wiring Modification Method	24
1) Wire modification method from 3 phases 3 lines 220VAC to 3 phases 4 lines 380VAC	
2) Wire modification method from 3 phases 4 lines 380VAC to 3 phases 3 lines 220VAC	
15. Default Values	26
1) Default value for user's menu	
2) Default value of supplier's menu	
3) Default value of edit menu	
16. Troubleshooting	27

1. Inspection and Operation

Please read through this instruction manual carefully to prevent any problems from misuse of the product. Please make this manual readily available to the final operator.

- This instruction manual may change without notice.
- Please contact YUDO for any questions or problems regarding the product or this instruction manual.
- It is illegal to copy this instruction manual without permission.

1) Product Check Please check if the product matches the product description you ordered. Please look for any damages or defects. Please contact YUDO if any problems are discovered.

2) Safety Precautions For safety, please use the product as instructed by this manual. Please comply with cautions mentioned below because they are very important for safety. Safety cautions consist of danger!, warning!, and caution! This instruction manual contains two types of safety notices, Warning! and Caution! YUDO is not responsible for any injuries/damages done by negligence or by not following the instruction manual.

Danger



- (1) Please do not touch input terminals by any part of body or a conductor of electricity. It may cause electric shock.
- (2) Do not use if the power cable is damaged.

Warning



- (3) Be sure that the input power is rated and sequence of phases is correct in order to prevent from damage or fault.
- (4) Please do not supply power to the controller before complete the wirings in order to prevent from electric shock or damage.
- (5) Please do not install or store on places with flammable substance or explosive gas because this is not explosion proof.
- (6) Do not allow any screw, metal material, water, oil, etc. to go inside of controller.
- (7) Please do not modify or add components to the product. It may cause malfunction, electric shock, or fire.
- (8) Please power off before installation or dismantling. It may cause electric shock, malfunction, or fault.
- (9) Check that earth/ground connection is in good condition. (earth/ground connection is to prevent from electric shock. Please comply with this for safety.)

Caution



- (10) We reserve the right to change this instruction manual without notice.
- (11) Please check if the product matches the product description you ordered.
- (12) Please look for any damages or defects which can be caused during transportation.
- (13) Install controller in upright position.
- (14) Please do not install or store on places exposed to direct shock or mechanical vibrations.
- (15) Please do not install or store in dirty, oil, chemical, steam, iron (contamination level 1 or 2).
- (16) Do not clean the controller by agents such as alcohol, benzene, etc.
- (17) Please do not install or store on places with high electromagnetic interference.
- (18) Warm up the controller for more than 30 minutes if it's below 10°C.
- (19) Do inspect the controller carefully when it gets wet because it may cause electric leakage or fire.
- (20) Noise filter is recommended if power source generates noise.
- (21) Do connect the wirings after confirming the polarity of terminals.
- (22) Periodic maintenance is recommended to use this controller safely.
- (23) The components of this controller consist of consumable parts and warranty parts.
- (24) The warranty period of this controller including components is one (1) year in case of general use.

Safety marks

Marks	Description
	Protective Earth/ground
	Danger Electric Shock Risk
	Notice a high temperature

3) Operating Procedure

- (1) Check all of the cable connections of the mold (if required).
Be sure that all of the cables are free from wear or damage.
Check the thermocouple type.
- (2) Check wiring standards whether Yudo standard (power and thermocouple combined type) or DME standard, etc.
- (3) Check power/thermocouple cable specifications.
(connector size, number of pins)
- (4) Using an Ohmmeter, check the resistance and isolation of power cables.
Check the open thermocouple cables.
- (5) Connect power/thermocouple cables to the mold only after the mold is loaded on the injection molding machine.
- (6) Check the main input power disconnect to be sure it is in the OFF position prior to connection of the controller to the power source.
- (7) Connect the controller to the power source if the power source and controller's main input power are same. (Controller's main input power is shown on the label on the backside of controller cabinet. If you find the differences between actual main input power and power shown on the label, contact an authorized representative. Unless, it may cause damage to controller units and/or malfunction of controller.)
- (8) Check that the earth/ground connection is in good condition.
Ensure that the system and the mold have the same ground reference
* (Unless, noise may cause damage to fuse and/or triac, and it may cause injury.)
- (9) Switch the controller on.
- (10) Switch the controller unit on by pressing the button.
- (11) Enter the target temperature (SV : setting value).
- (12) Verify whether the actual temperature (PV : point value) reach to the target temperature (SV).

Caution



If the fan of backside of controller stops, it may cause the unit damaged.
Please confirm the fan is working.

2. Structure of Controller

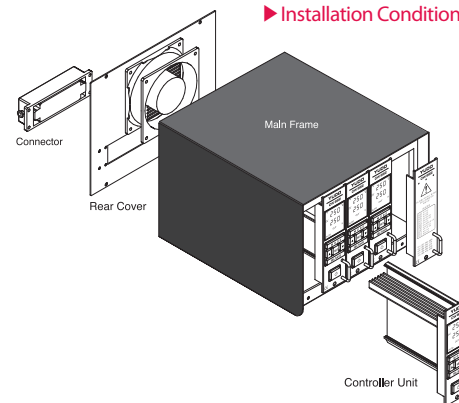

▶ Installation Condition : The bottom side is blocked for the safety.

3. Name of Components

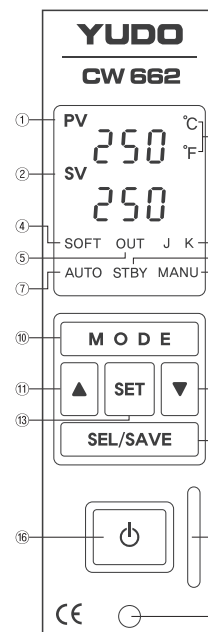

1. PV FND	Displays Measured Temperature (Red 4 Digit-Position Value)of Hot Runner System
2. SV FND	Displays the Set Temperature (Green 4 Digit-Set Value)of Hot Runner System
3. °C/°F LED	Temperature unit Setting value display
4. SOFT LED	Displays SOFT START operation
5. OUT LED	Displays Power Output State
6. J/K LED	Termocouple type (TC) Setting value display
7. AUTO LED	Displays Auto Mode is selected
8. STANDBY LED	Displays Standby Mode is selected
9. MANUAL LED	Displays Manual Mode is selected
10. MODE	Operation switch, User Mode operation key
11. ▲	Value Increase Key
12. ▼	Value Decrease Key
13. SET	Changing cipher key
* SET+MODE	Supplier's Menu
14. SEL/SAVE	Select mode (AUTO, STANDBY, MANUAL) & save the changes
15. Handle	
16. Power Switch	
17. Lock Bolt	

※ Caution. Keypad is made of Silicon rubber.
Don't touch the keypad by Drill, Ballpoint pen and the sharp edged things.

4. Controller Unit Specifications

1) Input Specifications	■ Thermocouple Type	TC-K (IEC-584), TC-J (IEC-584)
	■ Control Range	40 ~ 400°C
	■ Scan Rate	200 mS
	■ Scan Accuracy	±0.5% of F/S
	■ Compensable Temperature Variation	±2.0°C(-15°C ~ 65°C)
2) Output Specifications	■ Transmission Output	15A(Max 16.5A), 1 zone/Unit
	■ Output Mode	Phase Control, Zero Cross Control
	■ Output Resolution Limit	Phase Control : Approximately 1000 Resolution Zero Cross Control : 60Hz/50Hz-120/100 Resolution
	■ Period of renewal	200 mS
3) System Specifications	■ Input	
	Disconnection Detection	Up Scale action, and exceeding ±5% of input range
	■ Output	
	Output Mode	Phase Control, Zero Cross Control
	Display Range	40 ~ 400°C
	■ Control	
	Control Method	PV Preceding Derivative PID
	P BAND	0~ 600.0°C (at 0, output changes between On and Off)
	I TIME	0 ~ 600.0 Sec
	D TIME	0 ~ 600.0 Sec
	Hysteresis Range	0.1 ~ 5.0°C
	Self Tuning	Quick Auto Tuning , Full Auto Tuning
	■ Alarm	
	Range	± 99.9°C of Set Value (SV)
	Alarm Type	Alarm high, Alarm low
	■ Running the controller	
RUN	Auto run	
STANDBY	Duration, Target temperature	
MANUAL	Change input (PV) and output	
4) Environment Specifications	■ Operating Temperature	0°C ~ 50°C
	■ Operating Humidity	20 ~ 90%RH(Non-condensing)
	■ Storage Temperature	-25°C ~ 70°C
	■ Insulation Resistance	500Vdc, over 20MΩ (Input Power-F/G, Input/output-F/G)
	■ Withstand Voltage	1,500Vac, 50/60Hz 1 min (Input power-F/G, Input/Output-F/G, Input/Output-Input Power)
	■ Vibration Resistance	10 ~ 55Hz, bandwidth 0.75mm, X,Y,Z (3) directions 3 swings, 5 min/swing
	■ Impact Resistance	100 m/s ² , X,Y,Z (3) directions 3 times
■ Warming-up time	over 30 min	

5. Outline of controller and temperature control method

- 1) Outline of Controller** The controller is a device that has a function to maintain the desired temperature consistently by sensing the state of hot runner system with high-intellectual computer system named CPU and input proper power.
- 2) Temperature Control Method**
- (1) Temperature range : 40°C ~ 400°C / 104°F ~ 752°F
 - (2) Calibration of temperature deviation : It can calibrate the difference between actual and setting temperatures manually.
 - (3) Temperature control by : Auto Tuning , Auto PID, Manual PID control, On/Off control
 - ① Auto Tuning
Is a function to extract the control constant through analyzing the capacity of heaters and the heat constant of the mold (latent heat, radiant heat). It helps to make precise temperature control regardless of environmental change.
 - ② Auto PID control
Is a method in order to maintain temperature at the set temperature by controlling output power reflecting proportion, integration, and differentiation values.
 - ③ Manual PID control
Is a function to control by manual input of PID constant in case that temperature can not be controlled by auto tuning because the condition of heater is non-controllable.
 - ④ On/Off control
Is a function to relay tuning by inputting 0 at PID value in supplier's mode, in case that the temperature can not be controlled by auto tuning. (Overshoot can occur in this case).

6. Protective Functions

- 1) Ground Fault Inspection** Is a function to self-inspect short-circuit between heater and frame ground, and stop input power.
- 2) Thermocouple Disconnection Inspection** Is a function to inspect itself thermocouple disconnection, short-circuit or reverse connection, and stop input power.
- 3) Overcurrent Inspection** Is a function to stop input power to avoid damages by over current in case of heater short-circuit.
- 4) Soft-Start Function** When power on, output starts from 1% and increases by 1% per second up to 50%. The output stays at 50% until 110°C. This function prevents heaters from humidity-caused damage by preheating slowly.

7. Operation Mode

1) Operation Mode Selection
Operation Mode Select : **SEL / SAVE** key is converted by holding for 2 seconds.

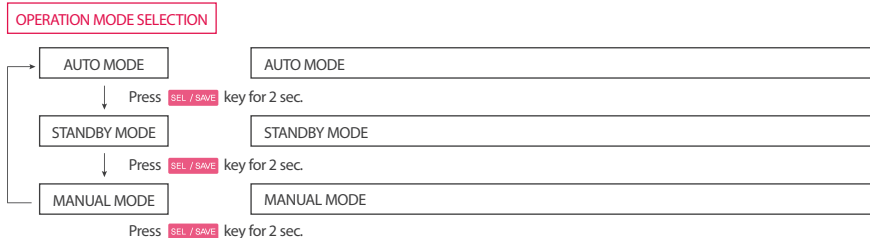

(1) AUTO mode

Normal operation mode in which the temperature is controlled and maintained automatically in accordance with the setting value.

① Display conversion : **MODE** key is pressed, the display on SV is converted as the following order. [Set Temperature] ▶ [Output%] ▶ [Ampere] ▶ [Set Temperature]

(2) STANDBY mode

Down the output power to the given rate for the given time, in production pause for a while.

① Holding **SEL / SAVE** key for 2 seconds in Auto mode will convert it into STANDBY mode. (Manual mode is automatically converted, in case STANDBY setting time is "0". Default 1 hour)

② Temperature setting value (SV) is changed into % rate on the basis of the set temperature during standby mode

③ STANDBY mode finished after the given time is up, and moves to AUTO mode. (Refer to page 9)

(3) MANUAL mode

Is a function to operate by manual on emergency that user can set output volume with **▲**, **▼** key.

① Push **SEL / SAVE** key 2 times each for 2 seconds in AUTO mode, and it will be converted into MANUAL mode.

② Available to change setting value (%) with **▲**, **▼** key.

2) Display Change
Display Change : Change the display by pressing **MODE** key in following turns.

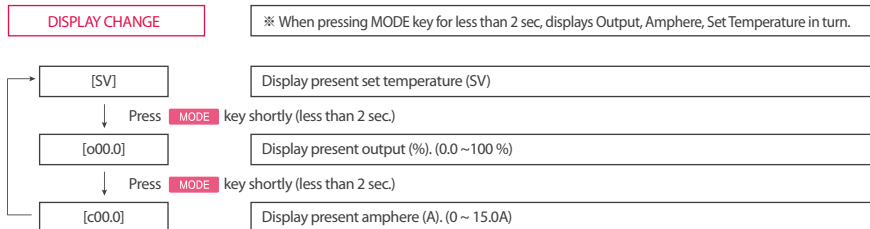

8. Menu Setting

1) User's Setting Menu (**PA-!**)

▶ Diagram of User's Setting Menu

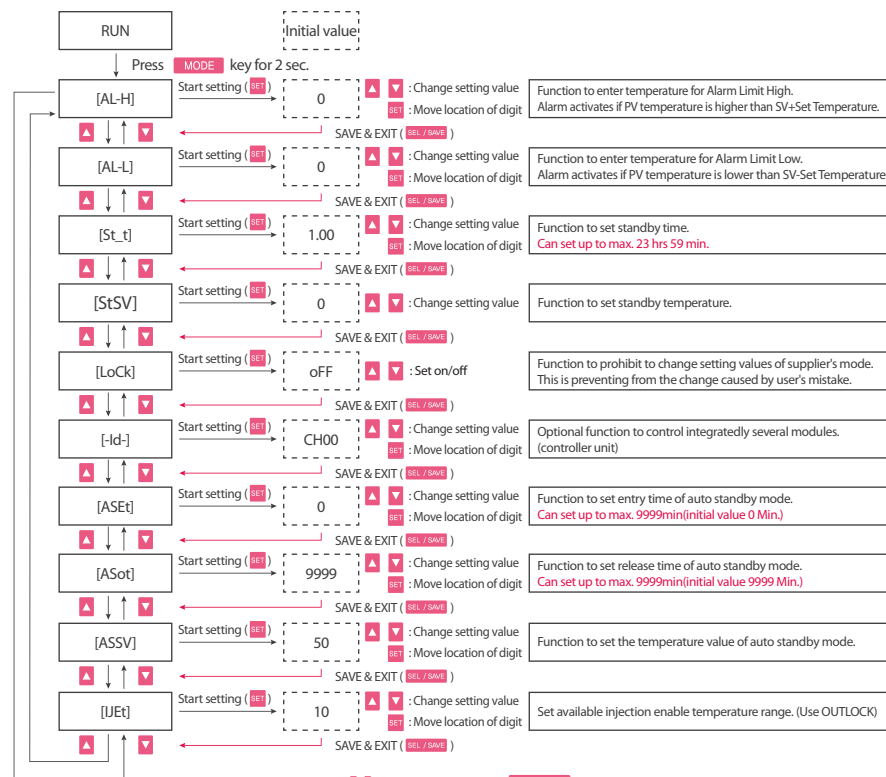

- PV displays **PA-!** by pressing **MODE** key for more than 2 sec. If taking off finger from **MODE** key, PV displays **AL-H** and user's menu is activated.
- Can select parameter function by pressing **▲**, **▼** key. Can change value by pressing **SET** key. Present setting values blinks every 100ms. Can change the number of digit by pressing **SET** key and can change the values by pressing **▲**, **▼** key.
- Pressing **SEL / SAVE** key saves changed setting value and return to user's setting menu.
- Complete the setting procedures by pressing **SEL / SAVE** key then return to RUN mode.

(1) **AL-H** (High Limit Alarm Function)

On the basis of the set temperature, when the temperature becomes higher than setting value, the AL-H function is operated.

- ① PV displays **PA-1** if press **MODE** key for more than 2 sec. PV displays **AL-H** if unpress **MODE** key, and SV displays AL-H value.
- ② If press **SET** key, setting value blinks every 0.1 sec. Can change number of digit by pressing **SET** key. Can change setting value by pressing **▲**, **▼** key. Setting range is 0~99. Factory default value is '0'.
- ③ Press **SEL / SAVE** key to complete the setting.

(2) **AL-L** (Low Limit Alarm Function)

On the basis of the set temperature, when the temperature is lower than the low limit setting value, the AL-L function is operated.

- ① If press **MODE** key for more than 2 sec, PV displays **PA-1**. Then if unpress **MODE** key, PV displays **AL-H**. If press **▲** key one(1) time, displays **AL-L**, SV displays AL-L value.
- ② If press **SET** key, setting value blinks every 0.1 sec. If press **SET** key, change the number of digit. Can change setting value by pressing **▲**, **▼** key. Setting range is 0~99. Factory default value is '0'.
- ③ Press **SEL / SAVE** key to complete the setting.

- ④ EX) If SV(Temperature Setting) : 200
AL-H (Alarm Limit High) : 50
AL-L (Alarm Limit Low) : -50 } are ?

- ▶ If sensing temperature is 250, Alarm Limit High (**AL-H**) is activated.
- ▶ If sensing temperature is 150, Alarm Limit Low (**AL-L**) is activated.

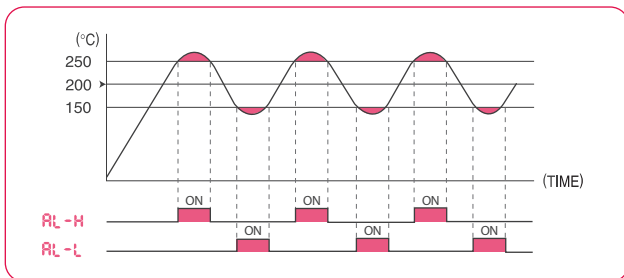

(3) **St.t** (STANDBY time setting)

- ① If press **MODE** key for more than 2 sec, PV displays **PA-1**. Then if unpress **MODE** key, PV displays **AL-H**. If press **▲** key two(2) times, PV displays **St.t**.
- ② If press **SET** key, setting value blinks every 0.1 sec. If press **SET** key, change the number of digit. Can change setting value by pressing **▲**, **▼** key. Setting range is 0~23 hours 59 mins. Factory default is 1.00 hour.
- ③ Press **SEL / SAVE** key to complete the setting.

(4) **St.SB** (STANDBY temperature setting)

- ① If press **MODE** key for more than 2 sec, PV displays **PA-1**. Then if unpress **MODE** key, PV displays **AL-H**. If press **▲** key three(3) times, PV displays **St.SB**.
- ② If press **SET** key, setting value blinks every 0.1 sec. If press **SET** key, change the number of digit. Can change setting value by pressing **▲**, **▼** key. Setting range is 0~400. Factory default value is '50'.
- ③ Press **SEL / SAVE** key to complete the setting.
- ④ EX) If SV(Temperature Setting) : 200
St.t (STANDBY time) : 1 hour (1:00)
St.SB (STANDBY temperature) : 140 } are ?

- ▶ STANDBY mode running time is 1 hour and STANDBY mode setting temperature is 140

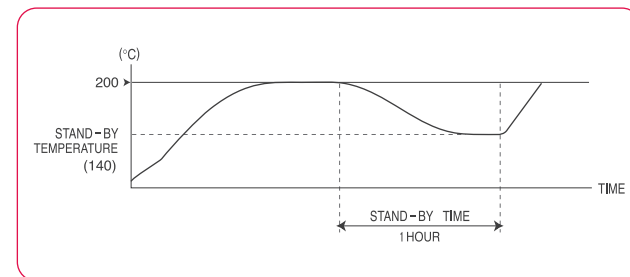

(5) **LoCb** (LOCK Key Software lock device)

This function is to protect to change the set parameters which are locked by parameter setting lock function by mistake.

- ① If press **MODE** key for more than 2 sec, PV displays **PA-!**.
Then if unpress **MODE** key, PV displays **RL-H**. If press **▲** key four(4) times, PV displays **LoCb**.
- ② If press **SET** key, setting value blinks every 0.1 sec. If press **▲, ▼** key, change ON/OFF.
- ③ Press **SEL / SAVE** key to complete the setting.

(6) **-! d-** setting (when use UNIT ID integrated control function, optional)

When want to control several modules (unit of controller) integrally, the computer at central control room recognizes each module by the designated identification number.

- ① This function requires an optional device for integrated control system.
- ② If press **MODE** key for more than 2 sec, PV displays **PA-!**.
Then if unpress **MODE** key, PV displays **RL-H**. If press **▲** key five(5) times, PV displays **-! d-**.
- ③ If press **SET** key, setting value blinks every 0.1 sec. If press **SET** key, change the number of digit. Can change setting value by pressing **▲, ▼** key. Setting range is 0~99.
Factory default value is '0'.
- ③ Press **SEL / SAVE** key to complete the setting.

(7) **ASeE** (AUTO STANDBY Entry time setting)(Inter-Lock Option)

Function to set the time to operate auto standby mode by checking certain time of status that keep no injection signal

- ① if press **MODE** key for more than 2sec, PV displays **PA-!** then if unpress **MODE** key, PV displays **RL-H**. if press **▲** key, six(6) times, PV displays **ASeE**.
- ② if press **SET** key, setting value blinks every 0.1sec. If press **SET** key, change the number of digit. Can change setting value by pressing **▲, ▼** key. Setting range is 0~9999min.
Factory default value is '0min'.
- ③ Press **SEL / SAVE** key to complete the setting.

(8) **ASot** (AUTO STANDBY release time setting) (Inter-Lock Option)

Function to set quit time of auto standby mode

- ① If press **MODE** key for more than 2 sec, PV displays **PA-!**.
Then if unpress **MODE** key, PV displays **RL-H**. If press **▲** key seven(7) times, PV displays **ASot**.
- ② If press **SET** key, setting value blinks every 0.1 sec. If press **SET** key, change the number of digit. Can change setting value by pressing **▲, ▼** key. Setting range is 1~9999min.
Factory default is '9999min'.
- ③ Press **SEL / SAVE** key to complete the setting.

(9) **ASSH** (AUTO STANDBY Temperature values setting) (Inter-Lock Option)

Function to set the temperature using upon entering auto standby mode

- ① If press **MODE** key for more than 2 sec, PV displays **PA-!**.
Then if unpress **MODE** key, PV displays **RL-H**. If press **▲** key eight(8) times, PV displays **ASSH**.
- ② If press **SET** key, setting value blinks every 0.1 sec. If press **SET** key, change the number of digit. Can change setting value by pressing **▲, ▼** key. Setting range is 0~400°C.
Factory default is '50°C'.
- ③ Press **SEL / SAVE** key to complete the setting.

(10) **! JEt** (injection enable temperature range setting) (Inter-Lock Option)

Function to set available injection temperature range by \pm set value

- ① If press **MODE** key for more than 2 sec, PV displays **PA-!**.
Then if unpress **MODE** key, PV displays **RL-H**. If press **▲** key nine(9) times, PV displays **! JEt**.
- ② If press **SET** key, setting value blinks every 0.1 sec. If press **SET** key, change the number of digit. Can change setting value by pressing **▲, ▼** key. Setting range is 0~50°C.
Factory default is '10°C' ($\pm 10^\circ\text{C}$)
- ③ Press **SEL / SAVE** key to complete the setting.

2) Supplier's Setting Menu (PA-2)

► Diagram of Supplier's Setting Menu

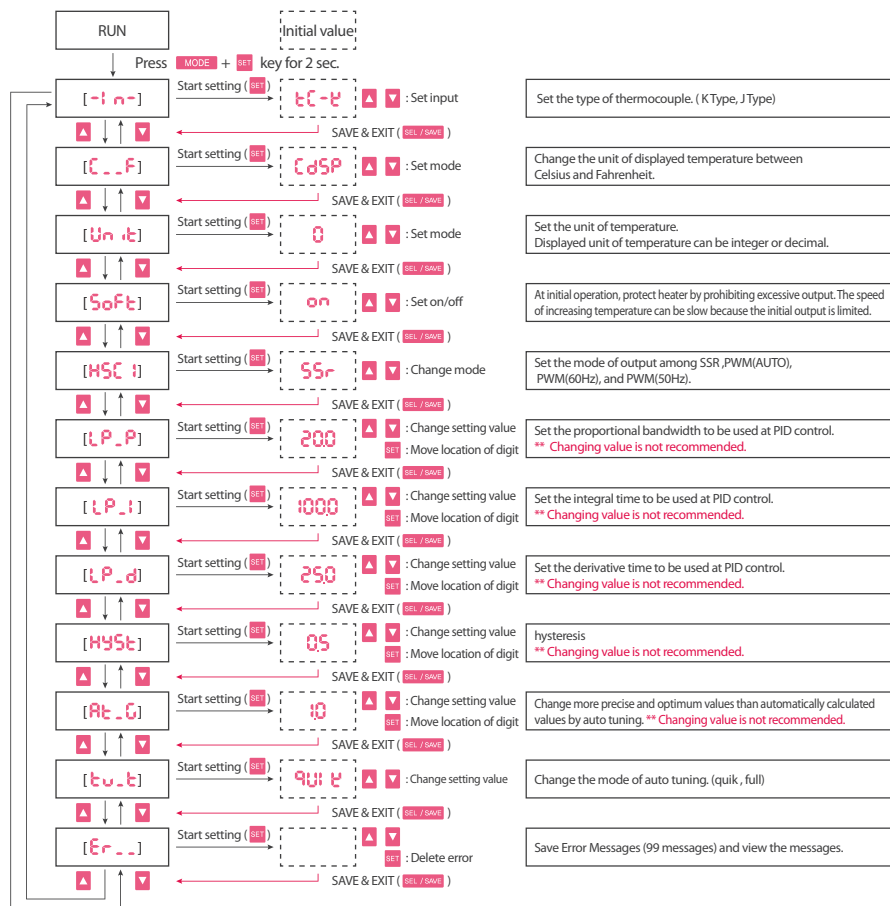

(1) -! n- (Function to select thermocouple)

- 1) If press **MODE** + **SET** key for more than 3 sec, PV displays **PA-2**. If unpress **MODE** + **SET** key, PV displays **-! n-** and SV displays the type of thermocouple.
- 2) If press **SET** key, setting value blinks every 0.1 sec. Can change the type of thermocouple by pressing **▲**, **▼** key.

- 3) Press **SEL / SAVE** key to complete the setting.
- 4) Setting can be done only when LOCK function is OFF.

(2) C..F (Celsius, Fahrenheit Display Function)

Two types of temperature unit; Celsius and Fahrenheit (°C/°F) can be displayed.

- 1) If press **MODE** + **SET** key for more than 3 sec, PV displays **PA-2**. If unpress **MODE** + **SET** key, PV displays **-! n-**. If press **▲** key one(1) time, PV displays **C..F**.
- 2) If press **SET** key, setting value blinks every 0.1 sec. If press **▲**, **▼** key, change the unit of temperature.
- 3) Press **SEL / SAVE** key to complete the setting.

(3) Unit (Temperature display digit setting function)

This function is to set the display digit of temperature in format of 1.0 and 0.1

- 1) If press **MODE** + **SET** key for more than 3 sec, PV displays **PA-2**. If unpress **MODE** + **SET** key, PV displays **-! n-**. If press **▲** key two(2) times, PV displays **Unit**.
- 2) If press **SET** key, setting value blinks every 0.1 sec. If press **▲**, **▼** key, change the display digit of temperature.
- 3) Press **SEL / SAVE** key to complete the setting.

(4) Soft (SOFT START setting function)

This function is to protect heater from excessive output at initial power supply. The speed of heating might be slow because the certain amount of output is limited at the initial operation.

- 1) If press **MODE** + **SET** key for more than 3 sec, PV displays **PA-2**. If unpress **MODE** + **SET** key, PV displays **-! n-**. If press **▲** key three(3) times, PV displays **Soft**.
- 2) If press **SET** key, setting value blinks every 0.1 sec. If press **▲**, **▼** key, change ON/OFF.
- 3) Press **SEL / SAVE** key to complete the setting.

(5) HSC ! (Output mode selection function)

This function is to select output mode. There are four(4) output modes; SSR, PWM(AUTO), PWM (60Hz), PWM (50Hz).

- 1) If press **MODE** + **SET** key for more than 3 sec, PV displays **PA-2**. If unpress **MODE** + **SET** key, PV displays **-! n-**. If press **▲** key four(4) times, PV displays **HSC !**.

- ② If press **SET** key, setting value blinks every 0.1 sec. Can change MODE setting by pressing **▲**, **▼** key.
- ③ Press **SEL / SAVE** key to complete the setting.

P_At : PWM AUTO MODE
P_60 : PWM 60Hz MODE
P_50 : PWM 50Hz MODE
SSr : SSR MODE

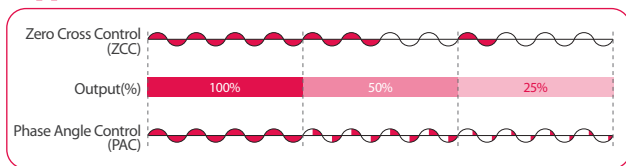

- (6) **LP_P** (Proportional-Integral-Derivative_ Proportional)
 This function is to set the proportional bandwidth at PID control. If the proportional bandwidth is wide, the speed to reach to the set temperature is slow because the control output is low. If the proportional bandwidth is narrow, the speed to reach to the set temperature is fast because the control output is high, but hunting (temperature goes up and down repeatedly for a certain period) can be occurred.
 (* We don't recommend to change the values.)
 - ① If press **MODE** + **SET** key for more than 3 sec, PV displays **PA-2** . If unpress **MODE** + **SET** key, PV displays **-! n-** . If press **▲** key five(5) times, PV displays **LP_P** .
 - ② If press **SET** key, setting value blinks every 0.1 sec. If press **SET** key, change the number of digit. Can change setting value by pressing **▲**, **▼** key. Setting range is 0~600.0. Factory default is '20.0'.
 - ③ Press **SEL / SAVE** key to complete the setting.

- (7) **LP_I** (Proportional-Integral-Derivative_ Integral)
 This function is to set the integral time at PID control. If the integral time is long, the speed to reach to the set temperature is slow. If the integral time is short, the speed to reach to the set temperature is fast, but hunting (temperature goes up and down repeatedly for a certain period) can be occurred. (* We don't recommend to change the values.)
 - ① If press **MODE** + **SET** key for more than 3 sec, PV displays **PA-2** . If unpress **MODE** + **SET** key, PV displays **-! n-** . If press **▲** key six(6) times, PV displays **LP_I** .
 - ② If press **SET** key, setting value blinks every 0.1 sec. If press **SET** key, change the number of digit. Can change setting value by pressing

- ▲**, **▼** key. Setting range is 0~600.0. Factory default is '100.0'
- ③ Press **SEL / SAVE** key to complete the setting.

- (8) **LP_d** (Proportional-Integral-Derivative_ Derivative)
 This function is to set the derivative time at PID control. This is the reaction on rapid temperature change. If derivative time is long, the reaction also goes big. If the reaction is big, hunting (temperature goes up and down repeatedly for a certain period) can be occurred because output changes much. (*We don't recommend to change the values)
 - ① If press **MODE** + **SET** key for more than 3 sec, PV displays **PA-2** . If unpress **MODE** + **SET** key, PV displays **-! n-** . If press **▲** key seven(7) times, PV displays **LP_d** .
 - ② If press **SET** key, setting value blinks every 0.1 sec. If press **SET** key, change the number of digit. Can change setting value by pressing **▲**, **▼** key. Setting range is 0~600.0. Factory default is '25.0'.
 - ③ Press **SEL / SAVE** key to complete the setting.

- (9) **HYSr**
 This function is to set the temperature range of hysteresis at PID control. (* We don't recommend to change the values.)
 - ① If press **MODE** + **SET** key for more than 3 sec, PV displays **PA-2** . If unpress **MODE** + **SET** key, PV displays **-! n-** . If press **▲** key eight(8) times, PV displays **HYSr** .
 - ② If press **SET** key, setting value blinks every 0.1 sec. If press **SET** key, change the number of digit. Can change setting value by pressing **▲**, **▼** key. Setting range is 0~9.9. Factory default is '0.5'.
 - ③ Press **SEL / SAVE** key to complete the setting.

- (10) **At_G** (Auto tuning Gain)
 This is auto tuning function. This is to change the PID values manually in order to get more precise and optimum values than automatically calculated PID values. (* We don't recommend to change the values.)
 - ① If press **MODE** + **SET** key for more than 3 sec, PV displays **PA-2** . If unpress **MODE** + **SET** key, PV displays **-! n-** . If press **▲** key nine(9) times, PV displays **At_G** .
 - ② If press **SET** key, setting value blinks every 0.1 sec. If press **SET** key, change the number of digit. Can change setting value by pressing **▲**, **▼** key. Setting range is 0~9.9. Factory default is '0.5'.
 - ③ Press **SEL / SAVE** key to complete the setting.

Gain < 1.0 : Response time gets faster, but hunting can be occurred.
 Gain = 1.0 : Use the value generated by auto tuning.
 Gain > 1.0 : Response time gets slower, but hunting can be reduced.

(11) **t.u.t** (Auto tuning type)

This is function to change auto tuning mode.

(*We don't recommend to change the values)

- ① If press **MODE** + **SET** key for more than 3 sec, PV displays **PA-2**.
 If unpress **MODE** + **SET** key, PV displays **-i n-**. If press **▲** key ten(10) times, PV displays **t.u.t**.
- ② If press **SET** key, setting value blinks every 0.1 sec. If press **▲**, **▼** key, change MODE. Factory default is **9.9: P**.
- ③ Press **SEL / SAVE** key to complete the setting.

(12) **Er...** (Error Messages)

From recent first to 20th error message are saved in memory.

- ① If press **MODE** + **SET** key for more than 3 sec, PV displays **PA-2**.
 If unpress **MODE** + **SET** key, PV displays **-i n-**. If press **▲** key eleven(11) times, PV displays **Er...**
- ② 20 error messages can be shown from saved memory by pressing **▲**, **▼** Key.

※ ERROR CODE TABLE

No	Error Message	Description	Reset
1	AdcE	CT sensor of controller unit failed	Checking
2	rJCE	Internal temperature sensor of controller unit (RJC) failed	SET key
3	tCoP	Thermocouple Open	SET key
4	tCrE	Sensor reversed	SET key
5	HtSt	Shorted Heater	Checking
6	HtOP	Open Heater	Checking
7	trSt	Triac Short	Checking
8	GrSt	Ground fault	Checking
9	AL-L	Actual temperature drops down set point of alarm low	SET key
10	AL-H	Actual temperature exceeds set point of alarm high	SET key
11	FrEr	Supply Power Error	Checking
12	F-12	Fuse 1,2 failed	Checking
13	FU-2	Fuse 2 failed	Checking
14	FU-1	Fuse 1 failed	Checking
15	CtEr	CT Error	Checking
16	CALE	Calibration Error	Checking

3) Edit Menu (PA-3)

► Diagram of Edit Menu

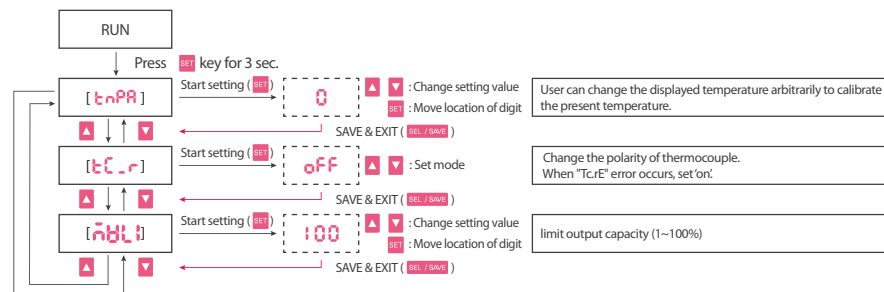

(1) **t n PA** (Temperature Correction)

User can calibrate present display temperature by entering arbitrary value.

- ① PV displays **PA-3** by pressing **SET** key for more than 3 sec.
 If unpressing **SET** key, PV displays **t n PA**, SV displays deviation calibration setting value.
- ② If press **SET** key, setting value blinks every 0.1 sec. Can change setting value by pressing **▲**, **▼** key. Setting range is -50~50. Factory default is '0'.
- ③ Press **SEL / SAVE** key to complete the setting.

(2) **t Cr E** (Thermocouple reversed)

This is function to change the polarity of thermocouple sensor.

If **t Cr E** error occurs, this function can be run without modifying wiring.

- ① If press **SET** key for more than 3 sec, PV displays **PA-3**.
 If unpress **SET** key, PV displays **t n PA**. If press **▲** key one(1) time, PV displays **t Cr E**.
- ② If press **SET** key, setting value blinks every 0.1 sec. If press **▲**, **▼** key, can change ON/OFF.
- ③ Press **SEL / SAVE** key to complete the setting.

(3) **n BL I** (Manipulate Value Limit)

Function to limit output capacity of heater

- ① If press **MODE** key for more than 3 sec, PV displays **PA-3**.
 Then if unpress **MODE** key, PV displays **t n PA**.
 If press **▲** key two(2) times, PV displays **n BL I**.

- ② If press **SET** key, setting value blinks every 0.1 sec. If press **SET** key, change the number of digit. Can change setting value by pressing **▲**, **▼** key. Setting range is 0~100%. Factory default is '100%'.
- ③ Press **SEL / SAVE** key to complete the setting.

9. Reset Function

This is a function which initializes the setting values of user mode and supplier mode. Turn on the power switch while pressing both **MODE** key and **SET** key to display **rSEt** on SV and to initialize all setting values after displaying countdown on PV (from 3 to 0).

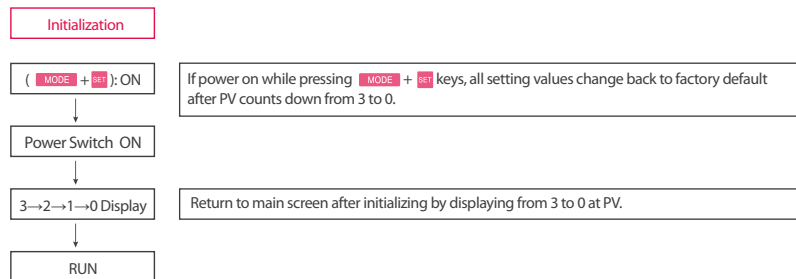

10. Integrated Control Function (Optional)

Central Control for every modules in the frame box can be executed effectively, with only one switch handling, i.e. STANDBY and LOCK ON for every module could be controlled simultaneously.

This function is available when optional device CGF570 is used.

1) AL/RE (Alarm/Reset Function)

Buzzer sounds when error occurs at more than one module. Mute buzzer easily by touching button one time. (Touching button makes buzzer off, but the cause of alarm is not removed.)

2) STBY (Integrated STANDBY function)

In order to stop the production for a while on the way of normal operation, you can select this function to reduce the power supply, with only one handling.

3) LOCK (LOCK ON function)

This is a security function to prevent from any modifications of setting. You can convert all modules into LOCK ON/OFF mode with only one handling.

11. Connector and Cable

Connector means a component attached to the end part of cable in order to make it easy to connect/disconnect the wire to the mold/controller. Various kinds of connectors are used depending on load capacities.

* Standard Spec. : Integrated Wire(Power+T/C)

* Optional Spec. : Separated Wire(Power, T/C)

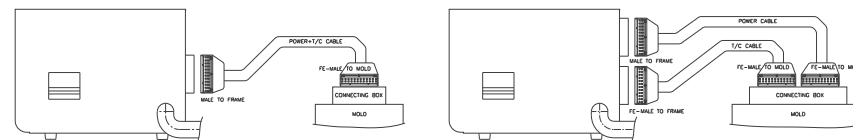

1) How to wire heater and T/C in connectors

4P Round Jack

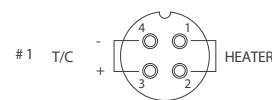

※ NOTE : # NO = ZONE NUMBER

24P Male standard connector
(5 ZONE~24 ZONE)

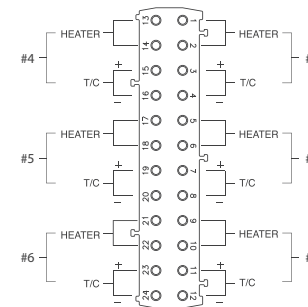

(1) Standard Specifications

Female connector is attached to the main frame, and YUDO supplies it with 4 pins, 16 pins and 24 pins.

No	Controller	Connector	Quantity
1	1 Zone	Undefined	1 EA
2	2 Zone	Undefined	1 EA
3	3~4 Zone	Undefined	1 EA
4	5~6 Zone	24PIN	1 EA
5	7~8 Zone	24PIN	2 EA
6	9~12 Zone	24PIN	2 EA
7	13~16 Zone	24PIN	3 EA
8	17~20 Zone	24PIN	4 EA
9	21~24 Zone	24PIN	4 EA

(2) Options

As for option in wiring, separated power lines from that of thermocouple can be selected depending on customer's preference. But also the other connector out of YUDO standard could be equipped when those are supplied from customer. In case that a cable is fabricated according to special order, controller connector must be fabricated in accordance with the cable specifications.

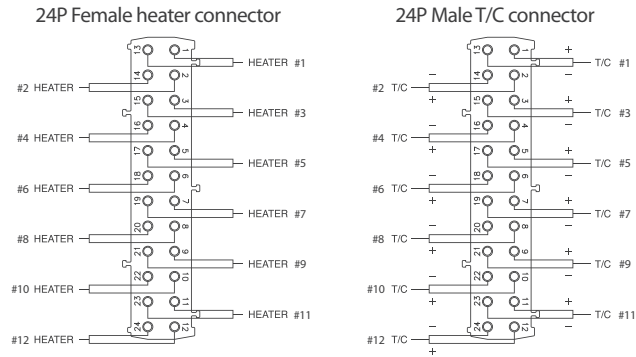

※ As for Zone No. : Please refer to the standard spec.

12. Diagram for Unit and Structure

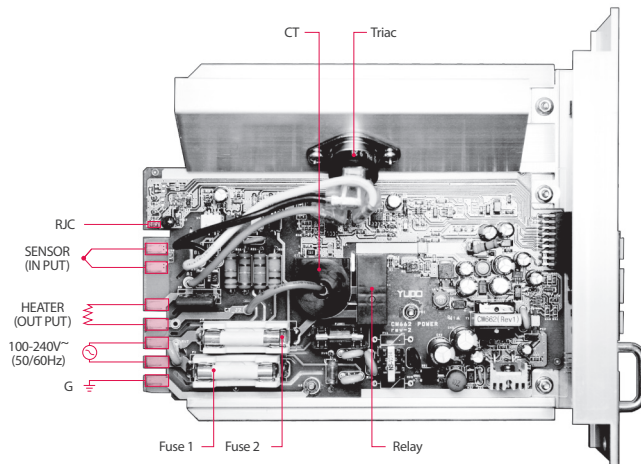

13. Electric Wiring Diagram

1) 220V (3 Phases 3 Lines Type) * Max. 240V

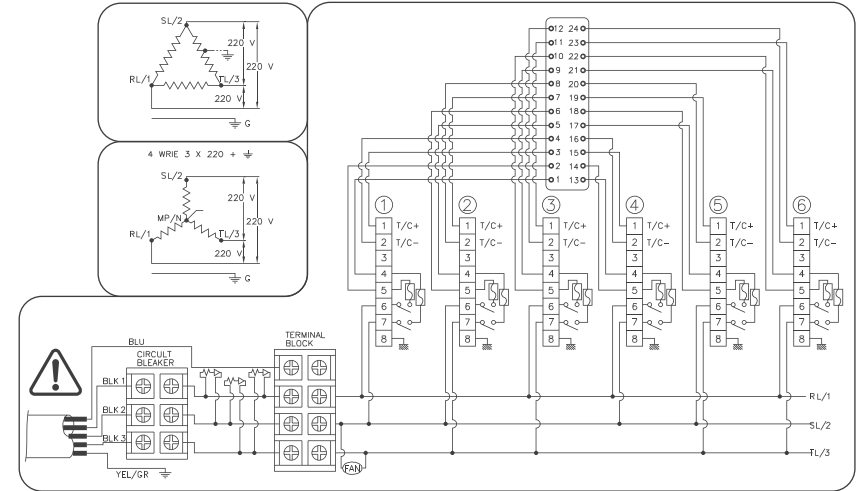

2) 380V (3 Phases 4 Lines Type) * Max. 414V

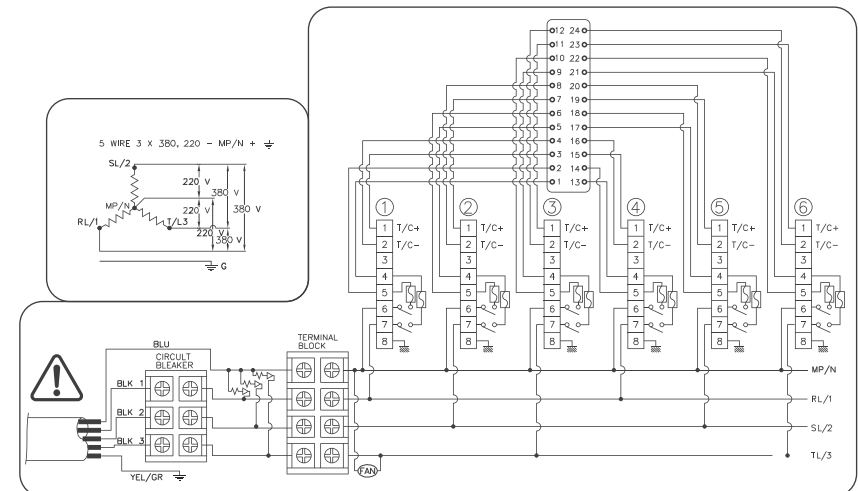

3) 220V (1 Phases 2 Lines Type)

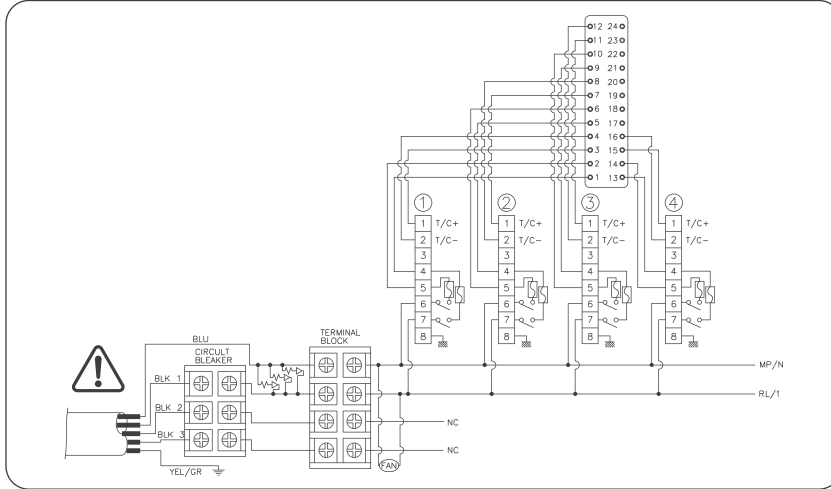

14. Wiring Modification Method

YUDO Temperature Controller operates with supply voltage 220~240V AC. But even in case of supply voltage 380~414V AC 3phase 4 line, by re-wiring as shown below, 220~240V AC can be taken between one phase(R, S or T) and Neutral(N).

YUDO Temperature Controller be supplied with wiring for supply voltage 220~240V AC unless special instruction.

Please check the current wiring.

Caution



Before re-wiring, make sure AC main power OFF and Power Switch OFF on controller.

1) Wire modification method from 3 phases 3 lines 220VAC to 3 phases 4 lines 380VAC

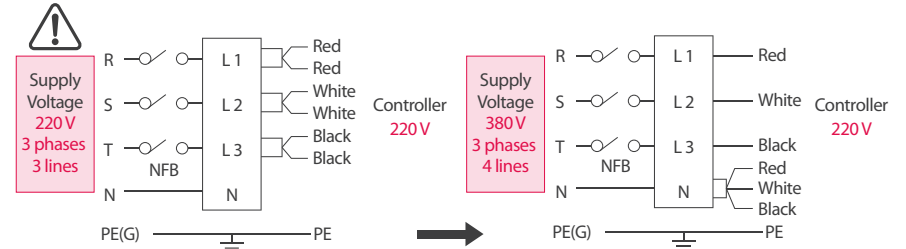

- (1) Power off the controller
- (2) Open the back cover of controller
- (3) Separate all three (3) blue-sleeved wires from L1, L2 and L3
- (4) Plug all three (3) blue-sleeved wires into N

2) Wire modification method from 3 phases 4 lines 380VAC to 3 phases 3 lines 220VAC

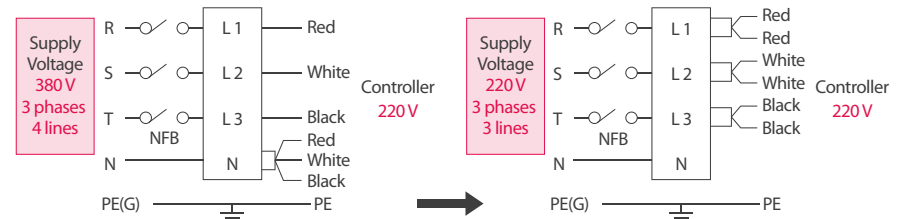

- (1) Power off the controller
- (2) Open the back cover of controller
- (3) Separate all three (3) blue-sleeved wires from N
- (4) Plug blue-sleeved RED wire into L1
WHITE wire into L2
BLACK wire into L3

Warning

PE(G) must be ground connection, do not permit to connect the Neutral. Manufacturer cannot be held responsible for any troubles from Above.

15. Default Value

1) Default value for user's menu (PA-1)

No	Menu	Default Value	Remarks
1	SV	40°C	SV(Setting Temperature)
2	AL-H	0°C	High Limit Alarm
3	AL-L	0°C	Low Limit Alarm
4	St_t	100 (1 hour)	STANDBY time
5	StSH	50°C	STANDBY temperature
6	LoCK	OFF	Lock Setting
7	-I d-	CH00	Unit Id
8	ASEt	0	Auto standby entry time
9	ASot	9999	Auto standby release time
10	ASSH	50°C	Auto standby temperature values
11	I JEt	10°C	Injection enable temperature range

2) Default value of supplier's menu (PA-2)

No	Menu	Default Value	Remarks
1	-I n-	CA-H	Thermocouple Type
2	C..F	CdSP	Celsius / Fahrenheit
3	Un it	0	Temperature Display Unit
4	Soft	on	Soft Start
5	HSC I	SSr	Output Method
6	LP_P	200	P
7	LP_I	1000	I
8	LP_d	250	D
9	HYS	05	Hysteresis
10	At_G	10	Auto tuning gain
11	tu_t	901	Self tuning
12	Er..		Error History

3) Default value of edit menu (PA-3)

No	Menu	Default Value	Remarks
1	tnPA	0	Temperature Correction
2	tC_r	OFF	TC Reverse MODE
3	HLI	100	Limit output capacity of heater

16. Troubleshooting

No	Error Message	Causes	Action
1	EOp	1. Sensor (thermocouple) is disconnected.	1. Replace or re-wire sensor (thermocouple) if it's disconnected after testing by a tester.
2	ECrE	1. Polarity (+,-) of sensor (thermocouple) are changed.	1. Change the polarity (+,-) of sensor (thermocouple) after checking connections of connectors of mold and controller.
3	HtOp	1. Heater is disconnected.	1. Replace heater if it's disconnected when you check the resistance of heater by a tester.
4	HtSt	1. Electric leakage of heater or short circuit of heater wire. 2. Capacity of heater is over 15A.	1. Check electric leakage of heater or short circuit of heater wire by a tester. 2. Replace the heater with a new heater (less than 15A).
5	trSt	1. Triac damaged.	1. Check the pin of triac. Fault: 2 or 3 pins are short circuited.
6	FU-1	1. F-1 fuse is disconnected by sudden over-current.	1. Replace F-1 fuse. (250V 25A)
7	FU-2	1. F-2 fuse is disconnected by sudden over-current.	1. Replace F-2 fuse. (250V 25A)
8	Temperature keeps going up.	1. Triac at radiation board of controller is damaged.	1. Check the pin of triac. Fault: 2 or 3 pins are short circuited.
9	Temperature keeps going down. Doesn't go up.	1. FS1 or FS2 fuse blown out. 2. Heater disconnected. 3. Heater wire disconnected. 4. Sensor (thermocouple) disconnected.	1. Replace fuse. 2. Check the resistance of heater by a tester. 3. Check the connection of heater. 4. Check the thermocouple by a tester.
10	Severe temperature deviation between set temp. and sensing temp.	1. Sensor contact is unstable. 2. Sensor types of controller and thermocouple are different.	1. Check the connection status of sensor. 2. Check the type of sensor.
11	Controller temperature doesn't go up, but heater of mold is overheated.	1. Thermocouple wire is pressed by mold. Or its sheath is peeled and its wire is in touch with mold or glass fibre sheath of wire.	1. Check and replace thermocouple.
12	Setting temperature of controller is equal to sensing temperature, but heater of HRS is overheated or not fully heated.	1. The types of sensors of mold and controller are different. EX) CA(K)→IC(J) IC(J)→CA(K)	1. Make sensor type of mold equal to the of controller.

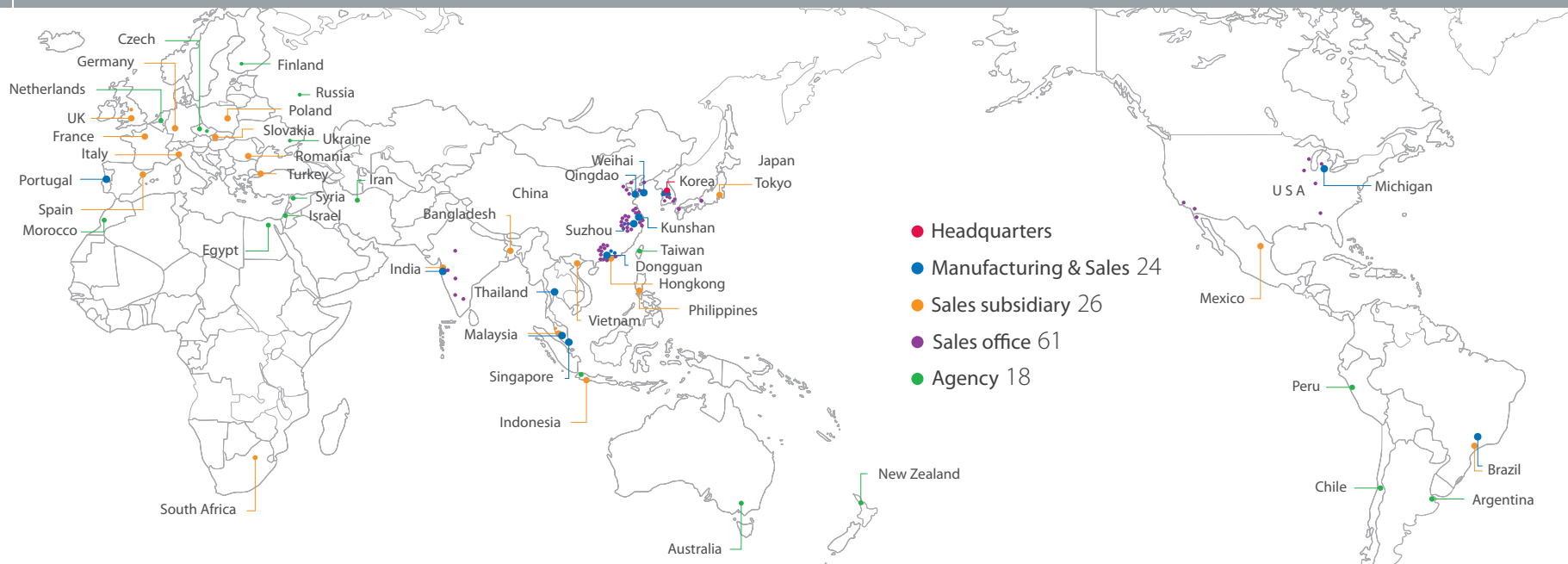

ASIA & OCEANIA

CHINA
GUANGDONG YUDO
HOT RUNNER SYSTEM CO., LTD.
Tel : + 86 769 8539 4466
e-mail : info@yudo.com.cn
YUDO (HONG KONG) ENTERPRISE CO., LTD.
Tel : + 852 2344 5180
e-mail : info@yudohotrunner.com.hk
YUDO (SUZHOU) H.R.S. CO., LTD.
Tel : + 86 512 6504 8882
e-mail : suzhou@yudosuzhou.com
YUDO (SHANGHAI) OFFICE
Tel : + 86 21 5138 6422
e-mail : shanghai@yudosuzhou.com
YUDO TIANJIN OFFICE
Tel : + 86 22 5839 9351
e-mail : tianjin@yudo.com.cn
YUDO (QINGDAO)
HOT RUNNER SYSTEMS CO., LTD.
Tel : + 86 532 8765 1698
e-mail : qingdao@yudoqingdao.com
YUDO (QINGDAO) TRADING CO., LTD.
(WEIHAI) OFFICE
Tel : + 86 631 567 2582
e-mail : wh@yudoqingdao.com
YUDO (QINGDAO) TRADING CO., LTD.
(DAILIAN) OFFICE
Tel : + 86 131 3002 3765
e-mail : dl@yudoqingdao.com
YUDO (NINGBO) OFFICE
Tel : + 86 574 8711 3033
e-mail : ningbo@yudosuzhou.com
WEIHAI YUDO MACHINERY CO., LTD.
Tel : + 86 631 597 2588
e-mail : weihaiyudo@yudosuns.com.cn
KUNSHAN YUDO-SUNS CO., LTD.
Tel : + 86 512 5791 0286

TAIWAN
YUDO CO., LTD. (TAIWAN BRANCH)
Tel : + 886 2 2205 6677
e-mail : yudotw@yudotw.com.tw

JAPAN
YUDO JAPAN CO., LTD.
Tel : + 81 3 5714 4801
e-mail : yuja@yudojpn.co.jp
NAGOYA OFFICE
Tel : + 81 52 745 0361
e-mail : yuja@yudojpn.co.jp
KYUSHU OFFICE
Tel : + 81 92 473 4808
e-mail : yuja@yudojpn.co.jp

INDIA
YUDO HOT RUNNER INDIA PVT. LTD.
Tel : + 91 250 3200922
e-mail : sales.mumbai@yudo.co.in
DELHI BRANCH OFFICE
Tel : + 91 120 454 9076
e-mail : service.delhi@yudo.co.in
PUNE BRANCH OFFICE
Tel : + 91 7798884634
e-mail : sales.pune@yudo.co.in
CHENNAI BRANCH OFFICE
Tel : + 91 8939625089
e-mail : sales.chennai@yudo.co.in

SINGAPORE
YUDO ASIAN PTE LTD.
Tel : + 65 6264 1616
e-mail : sales@yudowanco.com.sg

MALAYSIA
YUDO SDN BHD.
Tel : + 60 3 8945 2127
e-mail : sales@mawanco.com.my
YUDO ASIAN (MALAYSIA) SDN BHD.
Tel : + 60 7 2881 226
e-mail : ckcheng@mawanco.com.my

THAILAND
YUDO THAILAND CO., LTD.
Tel : + 66 2 174 7236-40
e-mail : matthew@yudowanco.co.th

BANGLADESH
YUDO (BD) PVT. LTD.
Tel : + 88 02 9014 632
e-mail : palas@yudohot.com

INDONESIA
PT YUDO INDONESIA
Tel : + 62 21 29083283
e-mail : ryu@yudowanco.com.sg
PT GAYA STEEL
Tel : + 62 21 89832277
e-mail : gayasteel@naver.com

PHILIPPINES
YUDO ASIAN PHILIPPINES INC
Tel : + 63 949 307 1950
e-mail : johnserdon@yudowanco.com.sg

VIETNAM
YUDO VINA CO., LTD.
HANOI OFFICE
Tel : + 84 43 78 77 179
e-mail : yuko.joseph@yudohot.com
HOCHIMINH OFFICE
Tel : + 84 938 36 23 77
e-mail : peterchin@yudowanco.com.sg

AUSTRALIA
STM AUSTRALIA PTY. LTD.
Tel : + 61 3 9805 9510
e-mail : sales@stm.net.au

NEW ZEALAND
STM SALES LTD.
Tel : + 64 9 8206454
e-mail : sales@stm.net.au

SYRIA
SAWAS TRADING GROUP
Tel : + 963 21 2254756
e-mail : swsco@scs-net.org

ISRAEL
ARAN R&D
Tel : + 972 4623 9019
e-mail : alon.berman@aran-rd.com

IRAN
YUDO IRAN
Tel : + 98 21 22066506-7
e-mail : info@yudo.ir

AMERICA & EUROPE & AFRICA

U.S.A.
YUDO INC. (Head Office)
Tel : + 1 734 744 8120
e-mail : yudo@yudousa.com
CENTRAL TERRITORY
Tel : + 1 614 600 6590
e-mail : ksalem@yudousa.com
MICHIGAN & WINDSOR
/ EASTERN CANADA
Tel : + 1 616 644 5615
e-mail : bthomas@yudousa.com
WESTERN TERRITORY
/ WESTERN CANADA
Tel : + 1 657 212 1827
e-mail : jbloomfield@yudousa.com
MID-EASTERN TERRITORY
Tel : + 1 937 478 9039
e-mail : rkilburn@yudousa.com
PACKAGING, CLOSURE & PET DIVISION
Tel : + 1 614 561 0017
e-mail : ffortorella@yudousa.com

U.K.
YUDO (UK) LTD.
Tel : + 44 1989 763423
e-mail : ruthd@yudo.co.uk

CZECH
YUDO CZ
Tel : + 420 724 358 612
e-mail : info@yudo.cz

RUSSIA
OOO YUDIX
Tel : + 7 495 723 5221
e-mail : commercial@yudo.su

PORTUGAL
YUDO EU SA.
Tel : + 351 244 570 390
e-mail : general@yudoeu.com

FRANCE
YUDO FRANCE
Tel : + 33 2 3277 4200
e-mail : flouhichi1008@yudoeu.com

SPAIN
YUDO IBERICA S.L.
Tel : + 34 93 715 81 22
e-mail : ysp.gavilar@yudoeu.com

ROMANIA
ROMOULD YUDO ROMANIA
Tel : + 40 212 272 115
e-mail : yudoro.nicu@yudoeu.com

TURKEY
YUDO TURKEY
Tel : + 90 212 320 95 63
e-mail : general@yudo.com.tr

ITALY
YUDO ITALY SH
Tel : + 39 2 99 551 78
e-mail : giovanni.pasolini@yudoitaly.com

GERMANY
YUDO GERMANY GmbH.
Tel : + 49 711 707 30370
e-mail : info@yudo-germany.com

NETHERLANDS
YUDO BENELUX
Tel : + 31 (0)13 5705252
e-mail : bvbueren@mouldservice.nl

SLOVAKIA
YUDO SLOVAKIA s.r.o.
Tel : + 421 904 116944
e-mail : yklee@yudostar.com

POLAND
YUDO POLAND SP. Z O.O.
Tel : + 48 607 352 875
e-mail : yudopl@yudoeu.com

FINLAND
YUDO Nordic Oy
Tel : + 358 3 616 1847
e-mail : info@yudonordic.fi

BRAZIL
SOLUTION BASE
Tel : + 55 47 3435 0022
e-mail : yudo@yudosa.com.br

PERU
TOTALMATRIX S.A.C.
Tel : + 51 1 447 1652
e-mail : contactoperu@totalmatrix.com

CHILE
TOTALMATRIX E.I.R.L.
Tel : + 56 2 671 8439
e-mail : contactoperu@totalmatrix.com

MEXICO
YUDO MEXICO S.A de C.V.(Head Office)
Tel : + 52 1 442 467 2598
e-mail : yuko.daniel@yudohot.com
TIJUANA OFFICE (Sales Office)
Tel : + 52 664 634 2936
e-mail : yuko.ken@yudohot.com

ARGENTINA
Modular Mold Normalizados S.A.
Tel : + 54 11 4756 7272
e-mail : info@modular-mold.com

EGYPT
C&C CORPORATION
Tel : + 20 2 2516 7926
e-mail : jinylee52@yahoo.co.kr

REPUBLIC OF SOUTH AFRICA
HESTICO PTY. LTD.
Tel : + 27 11 786 5228
e-mail : shaun.f@hestico.co.za