

# 用户手册

## User Manual

温控箱CW302 *TEMPERATURE CONTROLLER-CW302*



**YUDO**

CE

# CW302

感谢使用YUDO温控卡! Thank you for choosing YUDO.

使用产品前, 敬请仔细阅读此手册,

Please read this manual carefully before using the product.

如有任何不明处请与本公司联系。

Please contact YUDO about questions.



## 目录 CONTENTS

1、使用和操作温控箱前注意事项 .....	4
Items to check before using the Controller & Operation Procedure .....	20
2、温控箱的基本结构 .....	5
Basic Structure of Controller .....	21
3、温控箱概述 .....	5
Outline of Controller .....	21
4、温控箱的表芯规格 .....	6
Controller Unit Specification .....	22
5、各部位名称 .....	7
Name of Component .....	23
6、操作模式 .....	7
Operation Modes .....	23
1) 自动模式	
AUTO MODE	
2) 待机模式	
STANDBY MODE	
3) 手动模式	
MANUAL MODE	
7、菜单设定 .....	8
Menu Setting .....	24
1) 用户一级菜单设定	
User's first level menu settings	
2) 用户二级菜单设定	
User's second level menu settings	
8、错误功能显示 .....	13
Error Code Display Function .....	29
9、接线盒与线缆 .....	13
Connector and cable .....	29
10、接线端接线方法及示意图 .....	15
Diagram for Terminal Connection and Structure .....	31
11、电源接线图 .....	16
Electric Wiring Diagram .....	32
12、接线修改方法 .....	17
Wiring modification method .....	33
13、默认值 .....	18
Default Value .....	34
1) 出厂默认值	
Factory Defaults	
2) 用户可设定值	
User Settings Value	
14、安全标示 .....	19
Security Marks .....	35
15、故障现象及检查方法 .....	19
Check Point for Trouble Shooting .....	35

## 1、使用和操作温控箱前注意事项

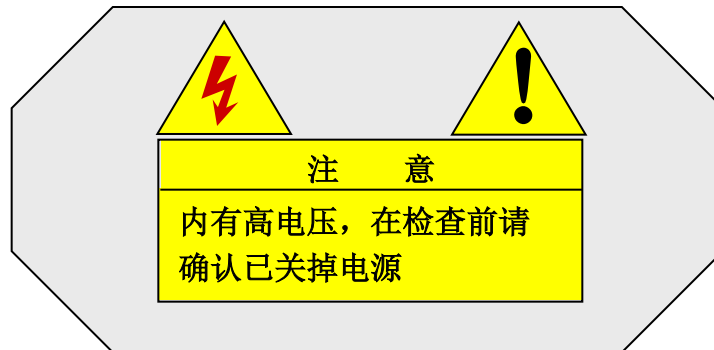

- ✓注意模具上的接线盒的接线情况和感温线类型
- ✓检查模具接线规格与温控箱接线规格是否相匹配
- ✓检查温控箱线缆是否匹配该温控箱
- ✓检查接线盒和线缆
- ✓检查发热线的电阻和绝缘状况，感温线是否连接线好
- ✓模具安装在注塑机上并接上线缆
- ✓检查电源开关和表芯开关是否关闭
- ✓如输入电压（220V/380V）符合温控箱的电压规格，接上电线（输入电压值注明在温控箱箱壳的标签上，如输入电压与标签上注明的电压值不相符，那么敬请垂询当地的YUDO公司，然后改正温控箱的接线方式，接错线会引起温控箱的不正常运行，而且会毁坏表芯）
- ✓确认温控箱的地零线（如不能区分零线（绿色），那么就易烧保险丝和可控硅）
- ✓打开温控箱电源主开关，然后打开表芯的电源开关
- ✓设定所需要的温度
- ✓检查设定所需要温度达到没有，温度是否稳定

注意：为了防止温度控制指令出故障，用于降温的风扇须一直运转。

## 2、温控箱的基本结构

安装条件:底部密封以确保安全

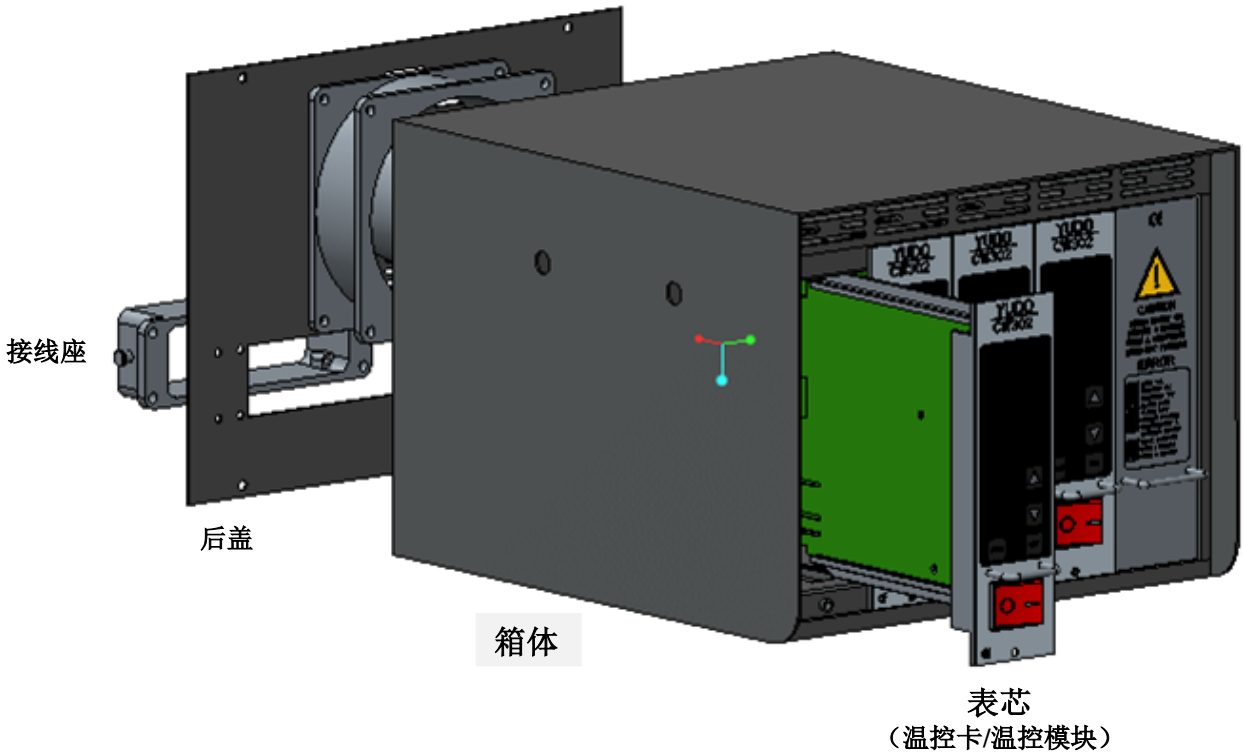

## 3、温控箱概述

温控箱是一种连续不断保持所需温度的设备，通过内装的智能电脑MICOM和输入适当电流，来探测热流道系统所处的温度。温度控制的精确性有几个重要因素。

### 1) PID模糊控制

通过比例控反映输出电流比例，统合指数和区别值的装置。

### 2) 自动调节

通过分析发热线的电容和模具的热常数、提供其主异因素的功能（具有潜热性和散热性），不管环境怎么变化它都有助于精确控制温度。

### 3) 输出模式

可根据不同的使用环境转换不同的输出方式。

### 4) PWM 模式

可达到精确是温度控制，但电源的噪声比SSR模式大得多。

### 5) SSR 模式

电噪声小，但对特定温度的控制特性比PWM方式略差一点。

## 4、温控箱的表芯规格

室内使用

电源输入电压：AC86—250V 50/60Hz 15A

载荷：15A, 50W-1650W(110), 100W-3300W(220V)

输出型：PWM(移相连续控制方式)

SSR(过零脉宽控制方式)

使用感温线类型：感温线(J或K型)

温度设定范围40℃-450℃, 104°F-842°F

温度稳定性±0.5%

温度控制类型：PID控制

周围温度：-10℃~50℃

海拔高度：可达2000M

过电压类别：II

灵活性：插入式指令舱

F1,F2:250V-15A(特殊保险丝)

F3:250V-1A

## USER'S MANUAL

## 5、各部位名称

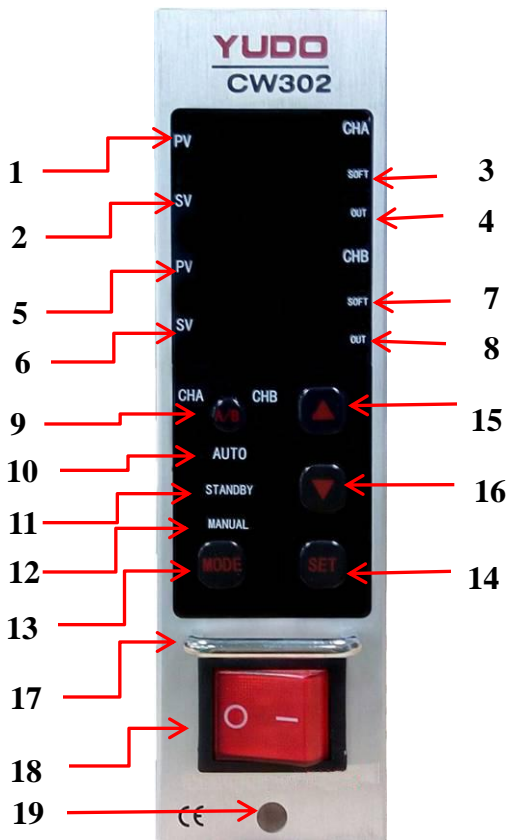

1	CHA PV	显示测量到CHA组实际的热流道系统温度 (红色数字4显示的数值)
2	CHA SV	显示设定CHA组的热流道系统温度 (绿色数字4显示的数值)
3	CHA SOFT	显示CHA组软启动操作功能
4	CHA OUT	CHA组输出指示灯
5	CHB PV	显示测量到CHB组实际的热流道系统温度 (红色数字4显示的数值)
6	CHB SV	显示设定CHB组的热流道系统温度 (绿色数字4显示的数值)
7	CHB SOFT	显示CHB组软启动操作功能
8	CHB OUT	CHB组输出指示灯
9	A/B	选择调试CHA组或CHB组
10	AUTO	显示自动模式已被选择
11	STANDBY	显示待机模式已被选择
12	MANUAL	显示手动模式已被选择
13	MODE	菜单转换键
14	SET	模式选择键(长按) 数字位移键(短按)
15	上键	增加键
16	下键	减小键
17	表芯拉手	
18	电源开关	
19	固定螺栓	

## 6、操作模式

►修改参数前,先确认CHA与CHB灯的状态,当CHA灯亮时,可修改CHA的相关参数,按 **A/B** 键可切换当前灯的状态。

1) 自动模式 这是正常工作模式,自动控制维持使用者设定的温度。转换界面:每按一次 **MODE** Key键,SV 显示变更为[设定温度]→[输出百分比]→[电流量]→[设定温度]。

2) 待机模式 正常生产过程中想中途待机等待的时候使用。

- AUTO 模式时 按 **SET** Key 3 秒钟后控制器切换为STANDBY 模式。
- 启动Stand-by功能后,温度值(SV)变更为Stand-by 温度(%比率) 工作时间为 Stand-by 设定时间。
- 经过Stand-by设定时间后模式自动变回为 AUTO 模式。

3) 手动模式 这是手动紧急工作模式,使用 **▲**, **▼** 键可任意地调节手动时的输出值。

- 在AUTO模式中连续按2次1秒钟 **SET** 键,运行状态变换为 MANUAL 模式工作。
- 感温线断路 **ECOP** 时或感温线短路 **ECSE** 时,用此方法转换为手动方式可继续生产。
- 通过 **▲**, **▼** Key按钮,可以变更手动输出功率值(0-99%比率)。

## 7、菜单设定

### 1) 用户一级菜单设定

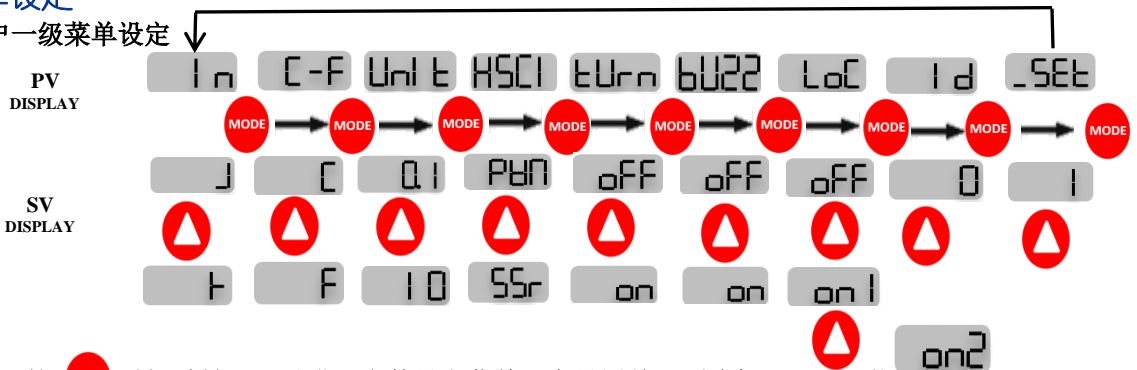

➤ 按 **MODE** 键3秒钟 可以进入参数设定菜单。在设置前必须确保LOC为OFF状态。

### LOCK (Key S/W锁定功能)

作为参数设定锁定功能,可以防止由操作者的失误引起的设定值的改变。

按 **MODE** 键3秒钟 PV显示 **In** 时,再连续按6次 **MODE** 键直到PV显示LOC为止。

这时SV显示 **on1** 或 **on2**, 按 **▲** 键或 **▼** 可转换为OFF, 才可以修改一级二级菜单。完成设定后同时按 **MODE** 键+ **SET** 键退出。

#### 1-1) **In** (感温线选择功能、J型或K型)

可以选择所需要的感温线的种类。

按 **MODE** 键3秒钟, PV显示 **In**, SV显示感温线类型 **J** 或 **t**。

用 **▲** 键可以选择感温线类型。

完成设定后同时按 **MODE** 键+ **SET** 键退出。

#### 1-2) **C-F** (摄氏、华氏显示功能)

温度单位可以用摄氏以及华氏(C/F)显示

按 **MODE** 键3秒钟, 再按1次 **MODE** 键 SV显示 **C** 或 **F**。

按 **▲** 键可以选择显示温度类型 **C** 或 **F**。

完成设定后同时按 **MODE** 键+ **SET** 键退出。

#### 1-3) **Unit** (设定温度显示单位功能)

这是温度显示单位功能, 温度单位可以设定为 1.0精度 和 0.1精度。

按 **MODE** 3秒钟, PV显示 **In**。

再按2次 **MODE** 键, PV显示 **Unit**, SV显示温度设定单位 **0.1** 或 **1.0**。

用 **▲** 键可以选择温度显示单位。

完成设定后同时按 **MODE** 键+ **SET** 键。

#### 1-4) **HSCI** (输出方式的选择)

因周围环境的不同，可选择PWM和SSR不同的输出方式。

按3秒钟  键时，PV显示  状态。

此时再连续按3次  键，PV则显示 ，SV显示（PWM/SSR）的输出方式。

可用  键选择不同的输出方式。



完成设定后同时按  键+  键退出。

#### 1-5) 工作状态下重整定功能（控温不准的情况下再整定）

这是温度控温不准的情况下再次整定，适合于工作状态下相互换卡，或者意外控温不准时用。

按  3秒钟，PV显示 。

再按4次  键，PV显示 ，SV显示为 。

用  键选择  状态,实现手动整定的功能。

完成 设定后同时按  键+  键退出。

#### 1-6) （蜂鸣器警报的开关功能）

按  3秒钟，PV显示 。





再按5次  键，PV显示 ，SV显示为 。

用  键可以选择  ,进行关闭。

完成 设定后同时按  键+  键退出。

#### 1-7) （Key S/W功能锁定）

作为参数设定锁定功能,可以防止由操作者的失误引起的设定值的改变。



按  键 3秒钟 PV显示  时，再连续按6次  键直到PV显示  为止。

这时SV显示 、 或 ，用  键 或  键 都可以转换,只有  状态下才可以修改一级二级菜单。如果  且包含设定温度都锁定，不可以改变参数。

完成设定后同时按  键+  键存贮设定。

#### 1-8) （Channel 设定选择）



此设计是便于客户区别每一个表芯在温控箱上的位置，确保产品质量及特殊的管理需求。

按住  键3秒，PV显示 。



再按7次  键，PV显示 ，按  和  键，可以从00-99之间设定值。

完成设定后同时按  键+  键储存。

#### 1-9) （菜单号）

按住  键3秒，PV显示 。

再按8次  键，PV显示 ，SV显示 ，为当前进入的是一级菜单，按  和 ，

当SV显示为  再按 1次  键可进入二级菜单。

## 2) 用户二级菜单设定

二级菜单构成图

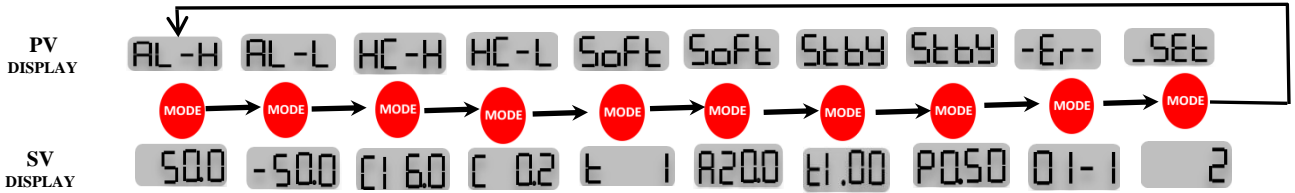

## 2-1) AL-H (上限报警功能)

以设定温度为基准，超过上限设定温度时警报自动提醒。

按 **MODE** 键 + **SET** 键3秒钟，PV会显示 **AL-H**，SV显示最高警报设定值。

用 **▲**，**▼** 键可设定00-99任意设定值，初始值设定成50。

完成设定后同时按 **MODE** 键+ **SET** 键退出。

## 2-2) AL-L (下限报警功能)

以设定温度为基准，下降到最低设定值时警报自动提醒。

按 **MODE** 键 + **SET** 键3秒钟显示 **AL-H**，再按一次 **MODE** 键PV显示 **AL-L**，SV显示最低警报值。

用 **▲** 键 **▼** 键从00-99任意设定，初始值设定成-50。

完成设定后同时按 **MODE** 键+ **SET** 键退出。

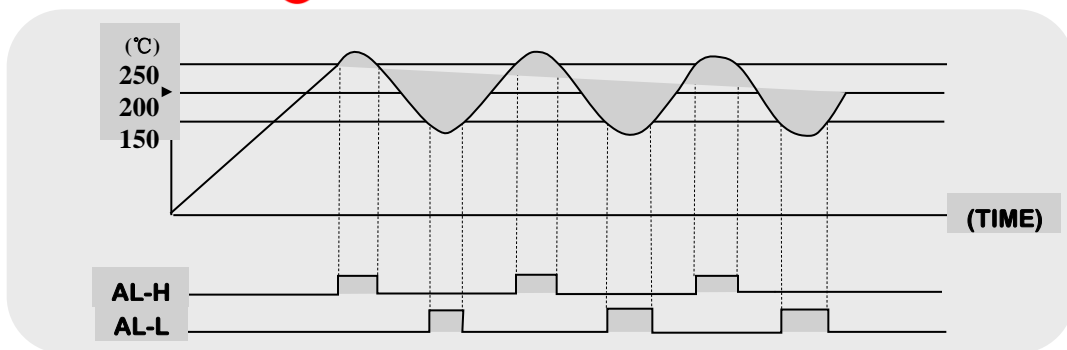

## 2-3) HC-H(最高上限电流值设定)

此功能用于检测发热线的异常情况，电流超过上限值时显示 **HESE**，并自动停止输出电流。

按 **MODE** 键+ **SET** 键3秒钟，PV 显示 **AL-H**，

按2次 **MODE** 键，PV显示 **HC-H**，SV显示上限电流值 **016.0**。

用 **▲** 或 **▼** 键完成参数设定。

完成设定后同时按 **MODE** 键+ **SET** 键退出。

2-4) **HC-L** (最小下限电流设定)

检测发热丝开路的功能，当加热圈最大输出电流小于下限电流值时，会提示 **HtOP**，并停止输出。

同时按 **MODE** 键+ **SET** 键3秒钟，PV显示 **AL-H**。

按3次 **MODE** 键，PV显示 **HC-L**。SV显示下限电流值 **[ 0.2 ]**。

用 **▲** 键与 **▼** 键完成参数设定。

按 **MODE** 键+ **SET** 键退出。

2-5) **SOFT** (SOFT START设定功能)

此功能目的是确认发热丝接线状态，低热平衡启动温控功能以避免因潮湿而引发的发热圈损坏。

在接通电源时，控制器以设定的输出功率及时间实现除湿功能。

预加热可以防止由湿气引起的发热丝的损坏。在模具初次使用、久未使用、或在潮湿环境下存放较长时间时，厂商建议操作员启动软启动功能以保护温控器和加热圈。前述情况下，建议设置软启动的功率为10%，时间为30分钟以上，确保模具中的湿气完全除尽。

(1) **t |** 设定软启动时间

同时按 **MODE** 键+ **SET** 键3秒钟，PV显示 **AL-H**。

再按4次 **MODE** 键，PV显示 **SOFT**，SV显示软启动的时间 **t |**，出厂设置1分钟。

用 **▲** 键与 **▼** 键调整参数设定。

(2) **A200** 设定软启动输出百分比

在SOFT时间显示状态下，按一次 **MODE** 键，就切换到软启动输出百分比设定参数的界面 **A200**，

用 **▲** 键与 **▼** 键调整参数，

完成后按 **MODE** 键+ **SET** 键退出。

2-6) **Stby** (设置待机模式)(1) **t1.00** (设定待机时间)

按 **MODE** 键+ **SET** 键3秒钟，PV显示 **AL-H**时，

再按6次 **MODE** 键，直到PV显示 **Stby** 为止。

用 **SET** 键实现小时和分钟的单位转换，用 **▲** 键 **▼** 键可以设待机时间为0到9小时59分。

## USER'S MANUAL

## (2) PQ50 (设定待机温度)

在STANDBY时间显示状态下按一次 **MODE** 键就切换到待机温度设定模式。

SV显示设定温度的比率值(P)。

用 **▲** 键, **▼** 键可设定 00----99% 设定值。

完成设定后同时按 **MODE** 键+ **SET** , 进行保存。

例如:设定温度(SV)设定为200,T(待机时间为1小时)P(待机温度%)为 $P \times 75\%$ 。

=>待机模式操作设定为1小时, 待机温度设定为 $150(75\% \times 200)$ 度。

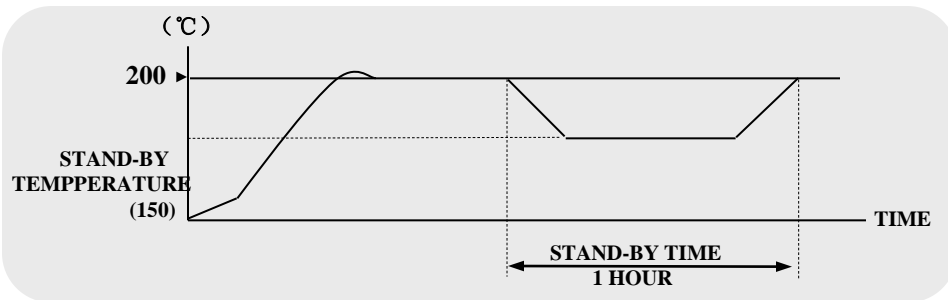

## 2-7) -Er- (错误信息储存功能)

按顺序保存最近发生的错误信息1-20条。

同时按 **MODE** 键+ **SET** 键3秒钟, PV显示 **AL-H** ,

这时再按8次 **MODE** 键, PV显示 **-Er-** , SV显示已发生过的错误代码 **01-1** ,

用 **▼** 键或 **▲** 键可以查看到最近20条的历史错误内容。

错误代码表:

错误代码	错误表示	错误内容
1	TCoP	感温线断路
2	TCST	感温线短路
3	TCRE	感温线接反
4	AL-H	温度超过上限温度
5	AL-L	温度下降超出下限温度
6	Ht. oP	发热丝断路
7	Ht. St	发热丝短路
8	tr. St	可控硅短路
9	FU-1	保险丝1断路
10	FU-2	保险丝2断路

## 8、错误功能标示

NO	故障分类	标示机能内容
1	感温线发生异常时	-根据报警提示有以下异常，分别为感温线开路 (tC, oP)、感温线短路 (tC, St), 感温线反接线 (tC, rE) 等可显示在PV上, 自动模式 (AUTO) 将停止输出, 处于关闭保护状态 (如果还需要继续使用, 可转换为手动操作 (MANUAL) 模式, 再设定所需的输出百分比保持一个固定的输出, 这样的功能可以预防因感温线的异常而引起的停止作业, 但是这时实际的温度无法测量, 需跟据现场实际情况人为改变输出量), 解决所有的问题后重新打开电源方可正常工作。
2	发热圈发生异常时	-可以确认HEATER的断线, 短路, 高电流等状态, 也可显示出 (SSR, TRIAC, RELAY) 等的短路。 -发生异常时发热圈断线 (Ht, oP), 发热圈短路 (Ht, St) 可控硅短路 (tr, St) 故障显示在SV上, 解决问题后重新打开电源方可正常运作。
3	FUSE 断线时	-保险丝断开时把所属的号码记录在SV上。-问题解决后重新打开电源方可以正常动作。

## 9、接线盒和线缆

接线盒是用于接在线缆末端, 线缆用以把电源连接于模具与温控箱上的配件, 根据所负荷的电容量, 采用不同的线缆。

.标准规格: 电源线与感温线于一体的单线缆

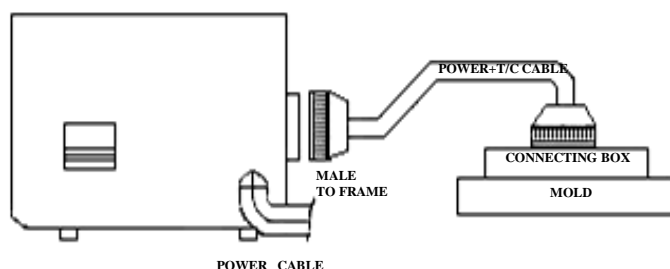

可选规格：电源线与感温线分开各成一线缆（共两组）

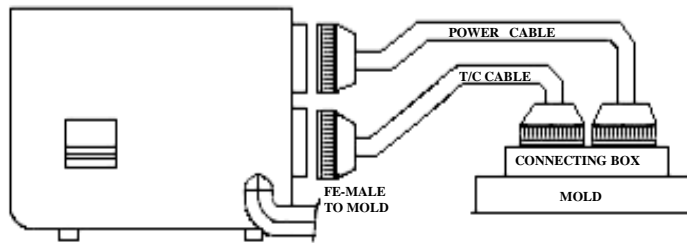

### 1) 怎样把感温线和发热线接到接线盒上

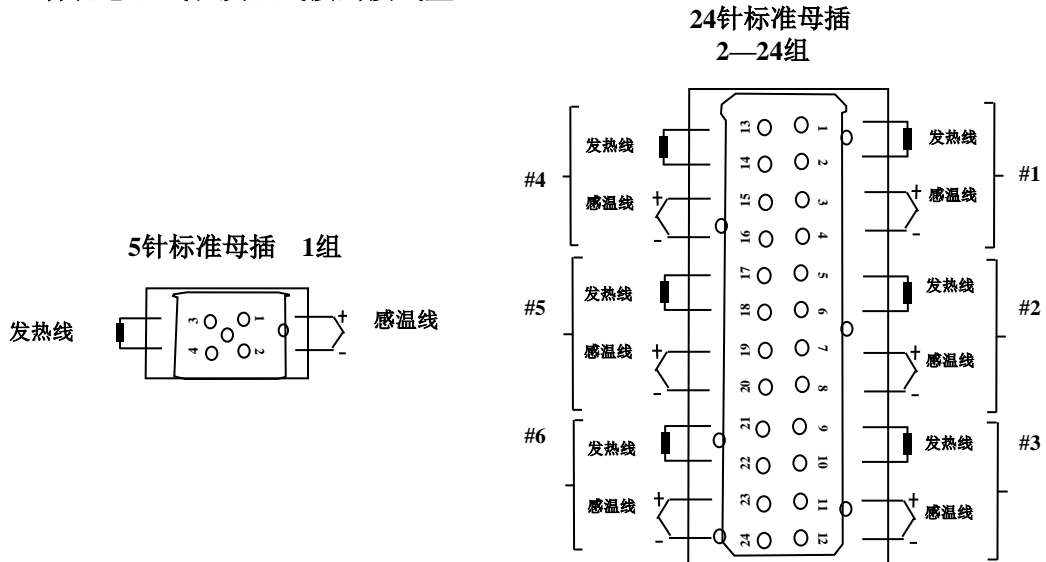

### 2) 标准规格

母插安置在主机上，YUDO提供5针，16针，24针插座,其规格标准如下：

编号	温控箱	接线盒	数量
1	1 组	5针插座	每一套1个
2	2 组	24针	每一套1个
3	3 - 4 组	24针	每一套1个
4	5 - 6 组	24针	每一套1个
5	7 - 8 组	24针	每一套2个
6	9 - 12 组	24针	每一套2个
7	13 - 16 组	24针	每一套3个
8	17 - 20 组	24针	每一套4个
9	21 - 24 组	24针	每一套4个

## 3) 选择

至于接线方法的选择，感温线与发热丝分开，此种方法的选择,因客户要求而定，但应客户的要求，非YUDO标准的插座亦能提供，也可以根据定单的特殊要求，改装线缆，根据线缆规格化配备温控箱插座。

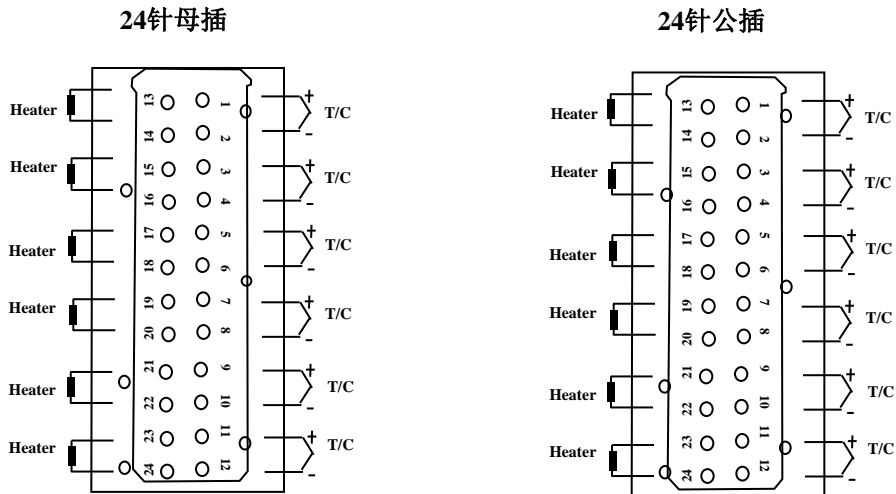

## 10、接线端接线方法及结构示意图

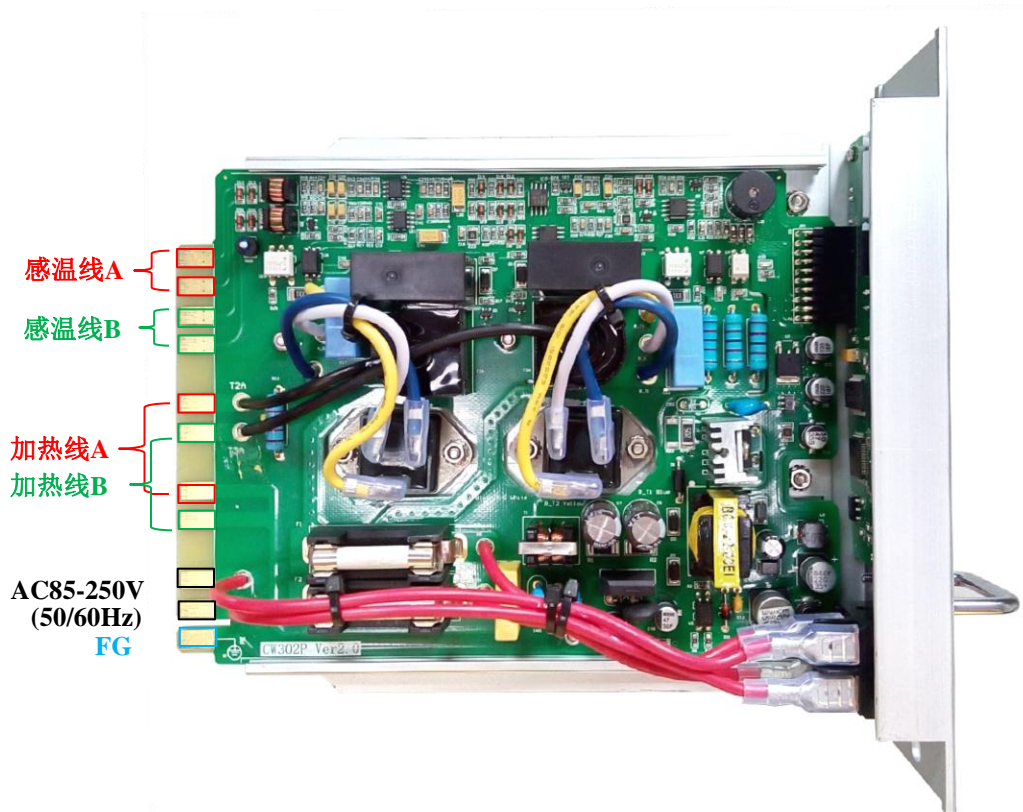

USER'S MANUAL

11、电源接线图

240V 3相3线型

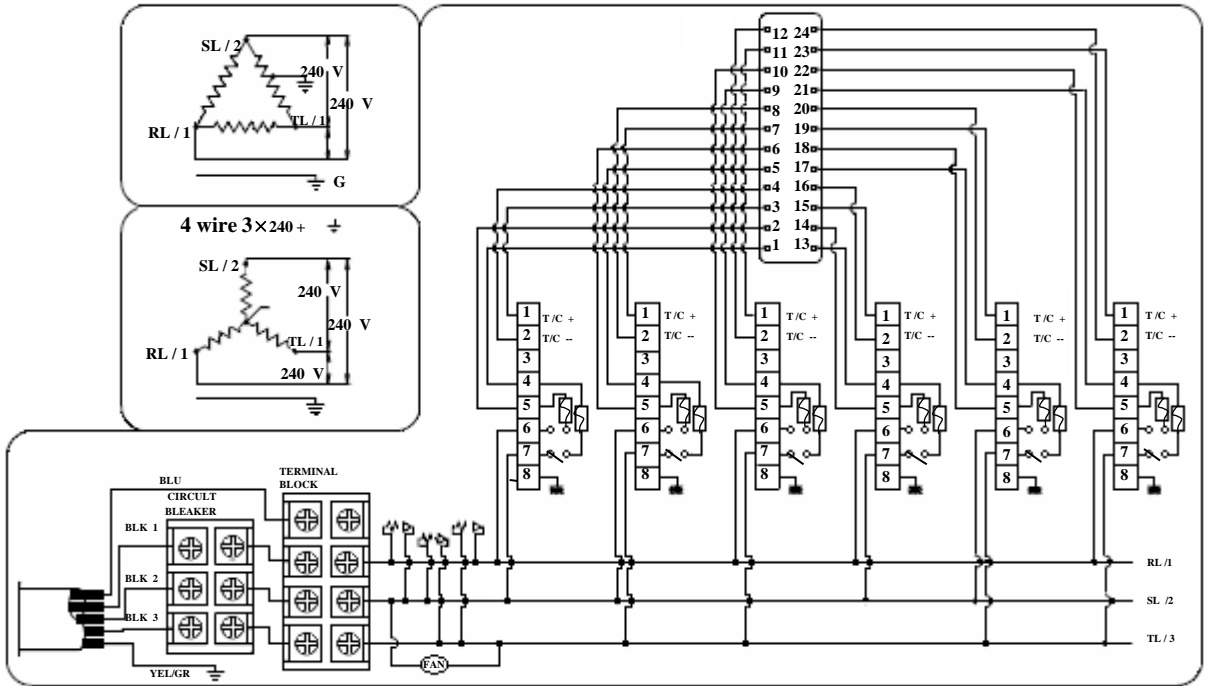

380 / 414V 3相4线型

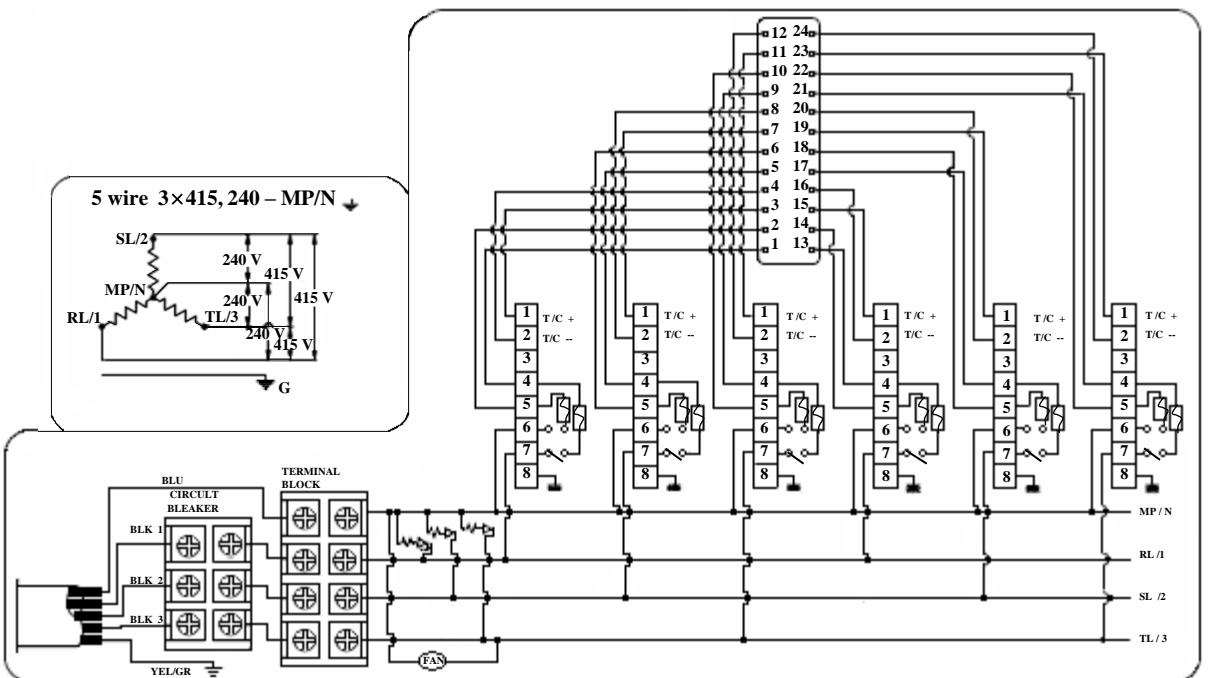

## 240V 单相2线型

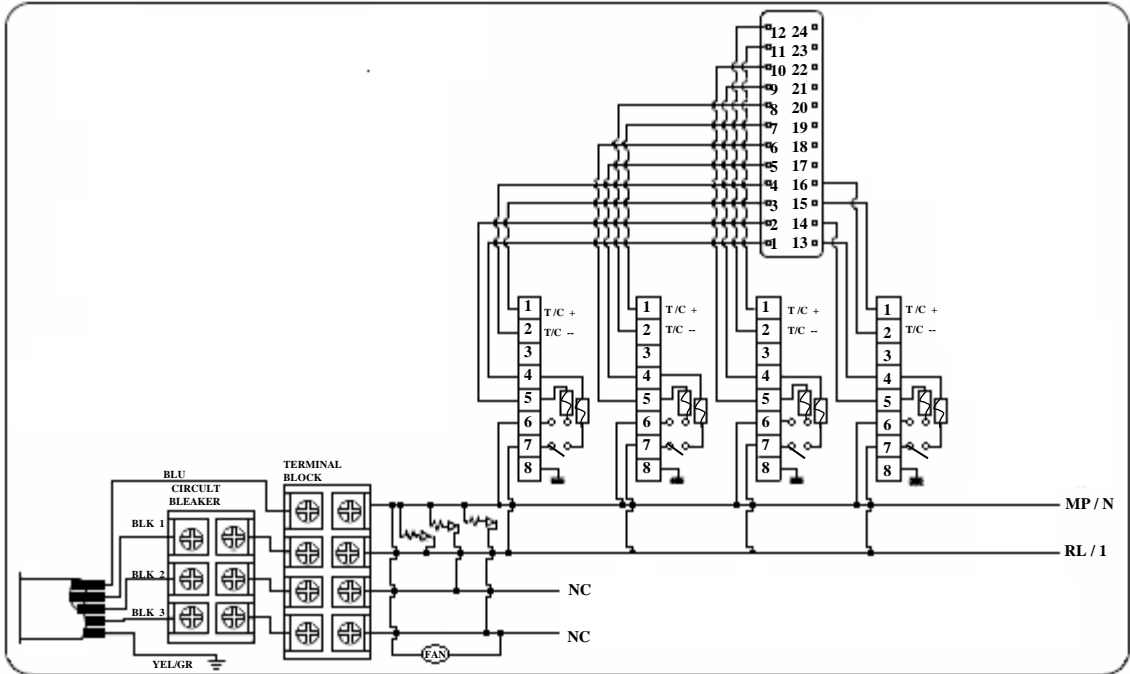

## 12、修改接线方法

YUDO温控箱操作使用的电压为220V-240V交流电，温控箱出厂时是使用380V – 450V 3相4线交流电，如果用户使用的是3相220V交流电，其接线方法如下。敬请检查电流接线方法。

**注意：**重新接线时，应确认交流电源主开关和温控箱电源开关关闭。

由380V 交流电改220V交流电改线方法如下：

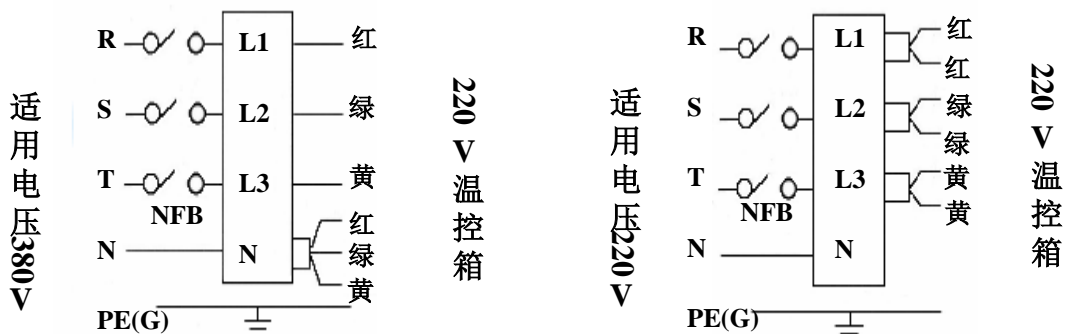

1. 切断电源。
2. 把温控箱后盖打开。
3. 把N及上所有的线取下。
4. 把带有黑色套管的红色线接到L1上。
5. 把带有黑色套管的绿色线接到L2上。
6. 把带有黑色套管的黄色线接到L3上。

由220V 交流电改380V交流电重新接线方法如下：

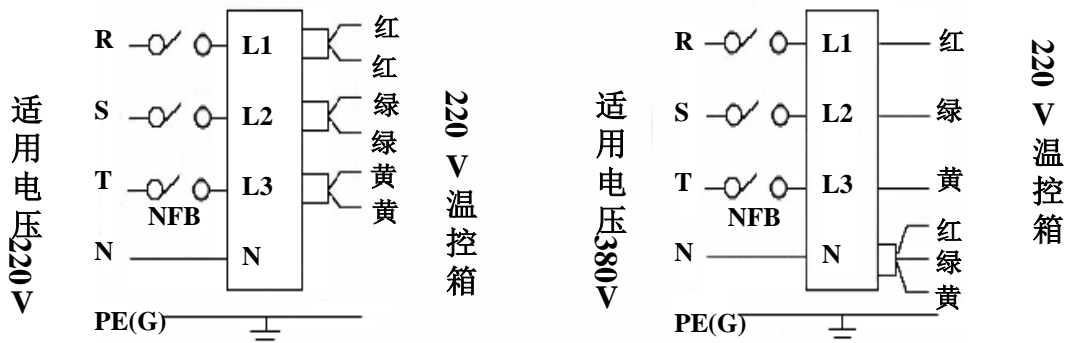

#### AC220V变AC280V步骤

- 1.切断电源.
- 2.把温控箱后盖打开.
- 3.把L1上带黑色套管的红色线取下.
- 4.把L2上带黑色套管的绿色线取下.
- 5.把L3上带黑色套管的黄色线取下.
- 6.把L1.L2.L3取下的线接到N上即可

**注意：**切勿把PE线插入N，如把PE线插入N可引发毁坏温控箱，如这种情况，YUDO公司将不承担责任。

## 13、默认值



### 1) 出厂默认值

序号	菜单	设定值
1	AL-H	50
2	AL-L	-50
3	HC-H	C16.0
4	HC-L	C 0.2
5	SOFT	T(时间) 1分钟
6		A(输出比例) 20%
7	STANDBY	T(时间) 1小时
8		P(比率) 50% (200℃)

### 2) 用户可设定值

序号	菜单	设定值
1	SV (设定温度)	200℃
2	IN (感温线类型) J、K	J
3	C-F (摄氏、华氏)	C
4	UNIT (温度单位)	0.1
5	HSCI (输出模式)	PWM
6	BURN (手动整定开关)	OFF
7	BUZZ (警报开关)	ON
8	LOC	ON1
9	ID	0

## 14、安全标示

	注意内部高电压
	维修之前请关闭电源

## 15、故障现象及检查方法

NO	现象	原因	对策及确认点
1	PV显示tC. oP	感温线断路	用万用表检查感温线，断路时换感温线
2	PV显示tC. St	感温线短路	先确认感温线和温控箱有无接触不良或者是否被模具压着
3	PV显示tC. rE	感温线的+极接反	确认装在模具和温控箱的插座连接状态后换感温线的极性
4	SV显示Ht. oP	发热丝断路	用万用表检查发热丝的电阻后断路时换发热丝
5	SV显示Ht. St	1发热丝漏电或者发热丝短路 2 发热丝的容量大于15A	用万用表检查发热丝的漏电或者发热丝的短路 换容量15A以内的发热丝
6	SV显示tr. St	装在表卡散热插座上面的可控硅损坏	确认可控硅的PIN不良：2个PIN或者3个PIN全部短路
7	SV显示FU-1	因瞬间的过大电流保险丝F-1断路	换保险丝 F1 (250V 15A)
8	SV显示FU-2	因瞬间的过大电流保险丝F-2断路	换保险丝 F2 (250V 15A)
9	温度不停的上升	装在表卡散热板上面的可控硅损坏	确认可控硅的PIN不良：2个PIN或者3个PIN全部短路
10	温度不停下降	1 F S2保险丝断路 2发热丝断路 3发热丝连接处断路 4感温线断路	1交换保险丝 2用万用表确认发热丝的电阻 3检查发热丝连接部位 4确认可感温线是否断路
11	设定温度和实际温度偏差很大	1感温线接触不良时 2感温线型号不符时	1检查感温线的接触状态 2确认可感温线型号
12	温控箱的温度正常但是发热丝温度过高	感温线压在模具上或包皮已破贴在模具上	感温线确认及更换
13	温控箱的设定温度与实际温度相同，但发热丝过热	模具的感温线与温控箱的感温线不一致，如：CA(K) -- IC(J) IC(J) -- CA(K)	统一模具的感温线与温控箱的感温线

## 1、 Items to check before using the Controller & Operation Procedure

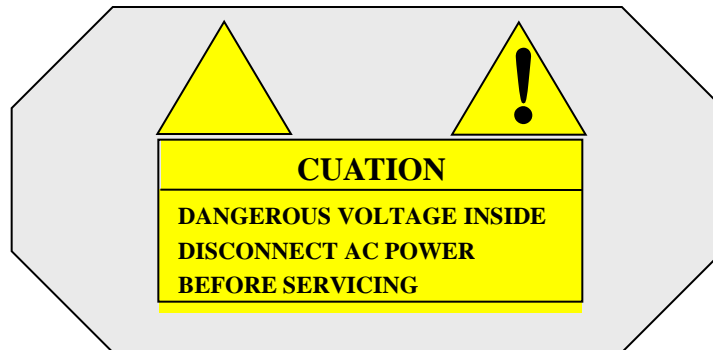

- ✓Check the wiring status of the connector attached to the mold and the type of T/C.
- ✓Check if the power lines are separated from the T/C lines and they are arranged in order.
- ✓Check if the trunk specification fits to the controller .
- ✓Check connection and wiring state of the trunk.
- ✓Check resistance and insulation state of the heater. then check if T/C wire is disconnected.
- ✓After the mold is fixed at the injection machine. connect the mold cable.
- ✓Check if the Power Switches of the Main & Units are Off.
- ✓if Input Voltage (240V/380V) fits to the controller voltage specification, connect Power Cable  
(Input power voltage is noted on the label of the controller case if the power input voltage does not fit to that written on the label, ask the local YUDO office and correct the controller wiring False wiring can cause malfunction of the controller and damage on the unit).
- ✓Ensure grounding wire of the controller, failure to do this (green line) can cause damage to fuse and Triac due to noise voltage.
- ✓Turn on the Main Power Switch first. Then, turn on the Unit Power switch.
- ✓Set up the appropriate temperature.
- ✓Check if the desired temperature is reached and stabilized.

**CAUTION: To prevent possible malfunction of the temperature control modules, the cooling fan MUST OPERATE AT ALL TIMES.**

## USER'S MANUAL

## 2、 Basic Structure of Controller

Installation Condition: The bottom side is blocked for safety!

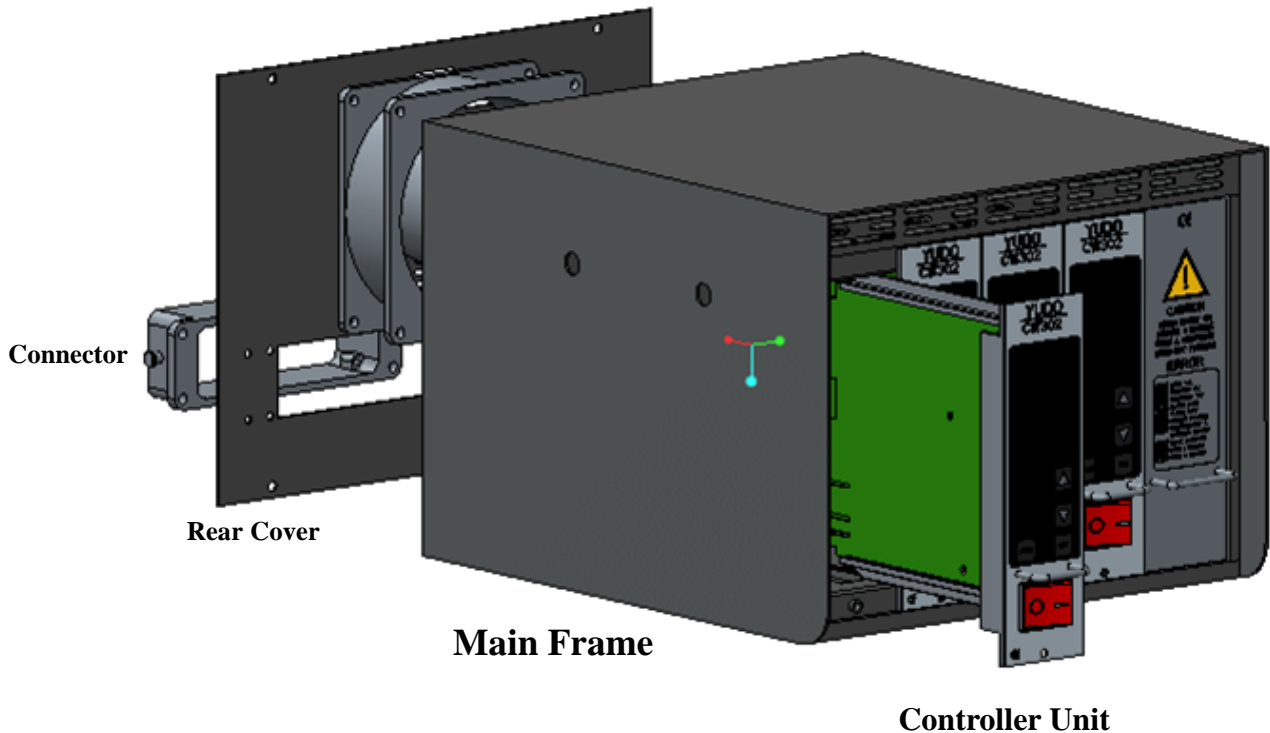

## 3、 Outline of the Controller:

The controller is a device whose function is to maintain the desired temperature consistently by sensing the state of Hot Runner System by utilizing a sophisticated computer system named MICOM to output the proper power level and frequency. It has several important functions for precise temperature control.

## 1)PID control:

It is a method implemented to maintain temperature at the set temperature accurately by controlling output power relative to proportion, integration and differentiation values.

## 2)Auto tuning:

Is a function to extract the governing factors through analyzing the capacity of the heaters and the heat constant of the mold (characteristics of latent heat and released heat). It helps to precisely control temperature regardless of environmental changes.

**USER'S MANUAL****3) Output Mode**

Output method can be changed depending on environment.

**4) PWM Mode**

Precise temperature control can be achieved, but electric noise is greater than that in SSR mode.

**5) SSR Mode**

Electric noise is small, but the specific temperature controlling ability is inferior to PWM mode.

**4、Controller Unit Specification****Indoor use**

**Powerinput Voltage: AC86-250V 50/60Hz 15A**

**Load capacity: 15A. 50W:1650W(110V) . 100W:3300W(220V)**

**Output Type: PWN(Pulse Width Modulation), SSR(Solid State Relay)**

**Sensor Type: Thermocouple (J or K)**

**Temperature Setting Range: 40°C to 450°C. 104°F to 842°F**

**Temperature Stability: +/- 0.5%**

**Temperature Control Type: PIDD CONTROL (Also called PID Control)**

**Surrounding temperature: -10°C to 50°C**

**Altitude: Up to 2000M**

**Over-voltage category : II**

**Degree of Mobility: Plug-in module**

**F1&F2: 250V-15A (Special Fuse)**

**F3: 250V-1A**

USER'S MANUAL

5、Name of Component

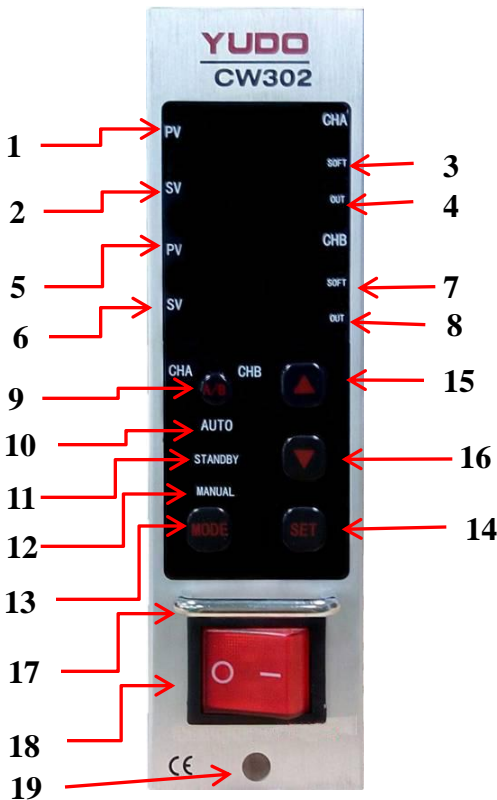

1	CHA PV	display the actual temperature of CHA ( the red number)
2	CHA SV	display the setting temperature of CHA ( the green number)
3	CHA SOFT	CHA soft operation
4	CHA OUT	diplay power output state of CHA
5	CHB PV	display the actual temperature of CHB ( the red number)
6	CHB SV	display the setting temperature of CHB ( the green number)
7	CHB SOFT	CHB soft operation
8	CHB OUT	diplay power output state of CHB
9	A/B	CHA or CHB for choosing
10	AUTO	display auto mode is selected
11	STANDBY	display standby mode is selected
12	MANUAL	display manual mode is selected
13	MODE	menu change key
14	SET	mode selected key(long pressing) or number moving key(short pressing)
15	UP	increasing value key
16	DOWN	descreasing value key
17	MODULE HANDLE	
18	MODULE POWER SWITCH	
19	MODULE LOCK BOLT	

6、Operation Modes

**CAUTION:** Before modifying parameters ,you must confirm it in which setting state CHA or CHB. When the CHA led is light, the parameters of CHA can be set. Change the state by pressing **A/B** key.

1) AUTO Mode

Normal operation mode in which the temperature is controlled and maintained automatically in accordance with the Set Degree. ①Display conversion: When **MODE** key is pressed, the display of SV is converted in the following order: [set temperature]→[output]→[ampere]→[set temperature] .

2) STAND-BY Mode

Reduces the output power to the given rate for a defined time period when it is needed to stop production for that time period and maintain a certain temperature.

- ①Holding **SET** key for 3 seconds in AUTO mode will convert it into STAND-BY mode
- ②Temperature setting value(SV) is changed into % rate on the basis of the set temperature during defined time period.
- ③STANDBY mode will cease after the defined time period, and revert to AUTO mode.

3) MANUAL Mode

User can adjust power output by using **▲** and **▼** key for emergency manual operation as determined by user.

- ①Press and hold **SET** key twice, for 3 seconds each time, AUTO mode will change to MANUAL mode.
- ②If sensor detects any disconnection of thermocouple open (tC/oP) or thermocouple short (tC/St), unit is switched to MANUAL mode automatically for emergency operation mode.
- ③Setting value(%) can be modified with **▲** and **▼** keys.

## USER'S MANUAL

## 7、 Menu Setting

## 1) User's first level menu setting

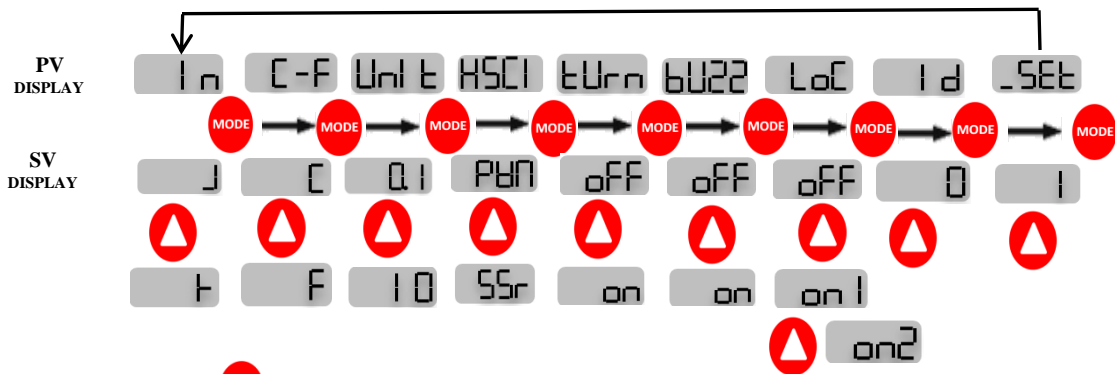

➤ Pressing **MODE** key for 3 seconds will open the first setting menu. Before setting parameters, **LoC** must be set to OFF status.

## LOCK (Key S/W Locking device)

You can lock your parameters by using this function to prevent changes due to user mistake.

Hold **MODE** key for 3 seconds, and find **In** is displayed on PV. Press it 6 more times until **LoC** is displayed on PV. Then you can see on SV: on1 or on2. Set it -oFF with **▲** key, which you can use to change the parameter. To save press **MODE** key and **SET** key together.

UNLOCK, follow above procedure, but chose on1 if you wish SV can change or on2 for SV no change.

## 1-1) In (Sensor selecting function)

Type of thermocouple can be selected to measure the Heater Temperature.

Hold **MODE** for 3 seconds, PV displays **In**, SV displays type **J** or **t**.

Press **▲** key to select type.

Save by pressing **MODE** and **SET** together.

## 1-2) C-F (Celsius and Fahrenheit degrees Selection)

Celsius or Fahrenheit degrees can be selected for temperature units.

Hold **MODE** for 3 seconds, press it 1 more time, PV displays **C--F**.

Press **▲** key to select **C** or **F** on SV.

Save by pressing **MODE** and **SET** together.

## 1-3) Unit (Temperature display Unit Setting)

This is a function to select temperature Units display. You can choose 1.0 or 0.1 for temperature unit

Hold **MODE** for 3 seconds, PV displays **In**.

Press it 2 more times, PV displays **Unit**, SV displays **10** or **01**.

Press **▲** key to choose type.

Save by pressing **MODE** and **SET** together.

## USER'S MANUAL

## 1-4) HSCI (Output type)

Based on the variables of the environment, PWM and SSR are available.

Hold  for 3 seconds, PV displays  status.

Press it 3 more times, PV will displays , SV displays PWM/SSr, two output types.

Press  to choose one.

Save by pressing  and  together.

## 1-5) Turn (If temperature control is not accurate, turn unit to MANUAL mode)

This is suitable for changing the card's operating mode under the condition when temperature control is not accurate.

Hold  for 3 seconds, PV displays  status.

Press it 4 more times, PV will displays , SV displays OFF.

Press  to choose ON, changes into MANUAL mode.

Save by pressing  and  together.

## 1-6) BUZZ (Turn on or off audible alarm)

Hold  for 3 seconds, PV displays  status.

Press it 5 more times, PV will displays , SV displays .

Press  to select .

Save by pressing  and  together.

## 1-7) LOCK (Key S/W Locking device)

You can lock your parameters, use this function to prevent the change of parameters by mistakes of user.

Hold  key for 3 seconds, and find  is displayed on PV.

Press it 6 more times,  is displayed on PV,  or  on SV.

Set it  with  key, then you can change parameters.



Save by pressing  and  together. (See also "LOCK" at beginning of this section)

## 1-8) Id (Channel Setting)

Client can use the function to assign each card with number 00-99. this is a convenient way to record settings for production control.

Hold  key for 3 seconds, and find  is displayed on PV.

Press it 7 more times,  is displayed on PV.

Set it with  and  key, to change the unit ID number.





Save by pressing  and  together.

## 1-9) \_SEt (Next Level Menu)

You can enter second level menu or third level menu with "2" or "4" number.

Hold  key for 3 seconds, and find  is displayed on PV.

Press it 8 more times,  is displayed on PV, SV displays "1". Changing number with

 and . If you want to enter the second level menu, choose "2" then press . If you want to enter the third level menu, choose "4" then press .

## USER'S MANUAL

## 2) User's second level menu setting

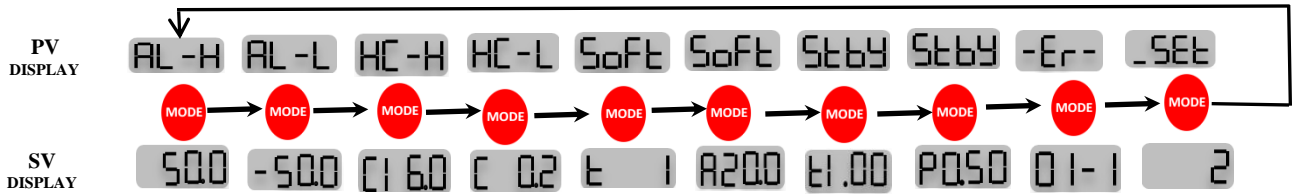

## 2-1) AL-H (High Limit Alarm Function)

When the temperature becomes higher than setting value, the AL-H function is triggered.

Hold **MODE** and **SET** for 3 seconds, PV will display AL-H, SV displays highest limit value.

Use **▲** and **▼** key to set the value 00 - 99. The initial value is set at 50 by the factory.

Save by pressing **MODE** and **SET** together.

## 2-2) AL-L (Low Limit Alarm Function)

When the temperature become lower than setting value, the AL-L function is triggered.

Hold **MODE** and **SET** for 3 seconds, PV will displays AL-H, press **MODE** 1 more time, PV displays AL-L, SV displays lowest limit value.

Use **▲** and **▼** key to set the value 00 - 99. The initial value is set at 50 by the factory .

Save by pressing **MODE** and **SET** together.

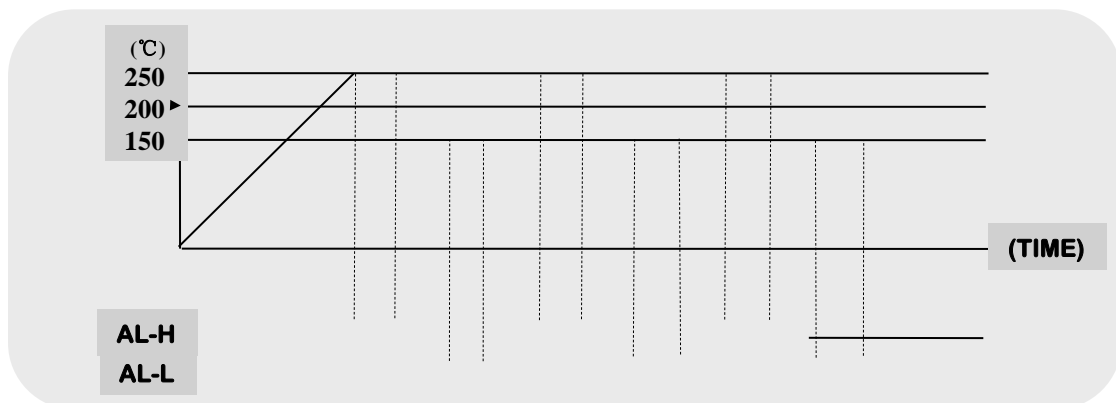



## USER'S MANUAL

## 2-3) HC-H (High Limit Current Setting)

This is provided to detect malfunction of the heater. It displays Ht.St sign, and stops output, when the current becomes bigger than the high limit.

Hold  and  for 3 seconds, PV will displays AL-H, press  2 more time, PV displays HC-H, SV displays highest limit value.



Use  and  key to set parameter.

Save by pressing  and  together.

## 2-4) HC-L (Low Limit Current Setting)

This is provided to detect malfunction of the heater. It displays Ht.oP sign and stops output when the current becomes smaller than the low limit.

Hold  and  for 3 seconds, PV will displays AL-H, press  3 more time, PV displays HC-L, SV displays lowest limit value.



Use  and  key to set parameter.





Save by pressing  and  together.

## 2-5) SOFT (Soft START setting)

This helps to avoid damage to heater caused by humidity- moisture in controller and heaters in the mold. By limiting output power and time when power is first applied to the heaters, the unit checks connection state of a heater and T/C's and initiates smooth control action at a low heat state. Preheating can prevent the controller and heaters from being damaged due to high moisture absorption content. If mold/heater is put into operation after prolonged storage period, especially in a damp environment, you should use the soft start function to protect the temperature controller and heaters.

(1)  | Set soft start time

Hold  and  for 3 seconds, PV displays AL-H.

Press  4 more times, PV displays  SV displays .It means 1 minute. To change with  and .

(2)  Set soft start output power rate

Press  1 more time again,SV displays ,SV displays .It means output power.To change with  and .

Save by pressing  and  together.

## USER'S MANUAL

## 2-6) STBY (STAND-BY Setting)

(1) **Et.00** (STAND-BY Time Setting)

Press **MODE** and **SET** for 3 seconds, PV displays AL-H, press **MODE** 6 more times, PV displays **StBy** SV display **Et.00**. For the conversion between hour and minute, press **SET** key.

Stand-by time can be adjusted from 0 (minutes) to 9 hours 59 minutes by using **▲** and **▼**.

(2) **P0.50** (STAND-BY Temperature Setting)

At the state of stand-by time setting, press **MODE** 1 more time again to change to stby temperature setting mode.

The % rate, based on the set temperature, **P0.50** is displayed on SV.

The value can be set in the range of 00-99% with **▲** and **▼**.

Save by pressing **MODE** and **SET** together.

For Example: In a case where the SV (temperature setting) is set at 200, T (stand-by time) is set to 1 hour and P (stand-by temperature) is set to P.75 then:

=>Stand-by mode is operated for 1 hour and temperature for stand-by mode is set as 150°C.

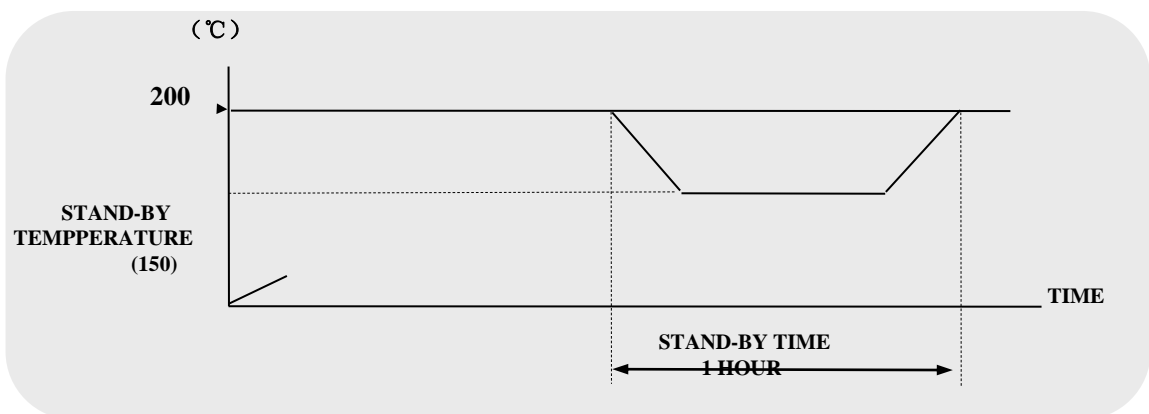

## 2-7) Error Code saving function

Error Codes are saved in memory in order of sequence with NO 1 being the most recent.

Hold **MODE** and **SET** for 3 seconds, PV displays **AL-H**.

Press **MODE** 8 more times PV displays **-Er-** and the stored error code on SV.

The other content can be displayed in sequence, by pressing **▲** and **▼** as necessary.

## ERROR OCCURRENCE SIGN

NO.	ERROR SIGN	DESCRIPTION
1	tC. oP	sensor open circuit
2	tC. St	sensor shortcircuit
3	tC. rE	sensor polarity reverse
4	AL-H	high limit alarm
5	AL-L	low limit alarm
6	Ht. oP	heater open circuit
7	Ht. St	heater short circuit
8	tr. St	triac short circuit
9	FU-1	fuse 1 disconnection
10	FU-2	fuse 2 disconnection

## USER'S MANUAL

## 8、 Error Code Display Function

N O	classification	Description
1	Malfunction of Temperature sensor (T/C)	-According to the alarm prompt has the following abnormalities, sensor open circuit (tC.oP), sensor short circuit (tC.St) and sensor reversed (tC.rE) on PV. Auto mode power output to heater will stop. If wanting to holding on,changing to manual mode and set a constant output rate. This function helps to prevent interruption in production due to malfunction of a sensor, but the actual temperature can't be measured.Output power can be adjusted manually as required to maintain temperature.When the problem is solved, power on to reset normal operation.
2	Malfunction on heater	-Open circuit, short circuit and excess current to heater can be detected. Short status of output device (SSR,TRIAC,RELAY) can be checked also. -On error occurrence, heater disconnection (Ht.oP), heater short (Ht.St) and triac short (tr.St) could be displayed on SV. When the problem is solved, power must be switched off then on to reset normal operation.
3	FUSE Disconnection	-In the case of a blown fuse, related fuse number is displayed on SV. -Turn off unit power switch, change fuse and turn power on to reset normal operation.

## 9、 Connector and Cable

Connector is a component attached to the end part of cable in order to make it easy to connect/disconnect the wire to the mold /controller . Various kinds of connectors are used depending on load capacities.

Standard Spec: Integrated wire (power+T/C)

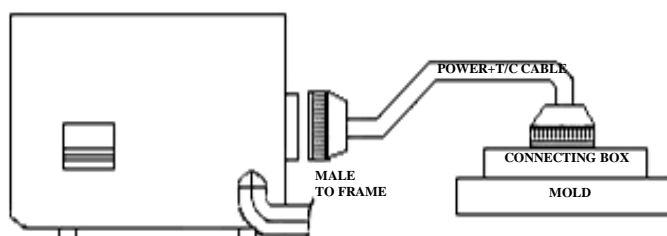

USER'S MANUAL

Optional Spec.: Separate cables for each (power +T/C)

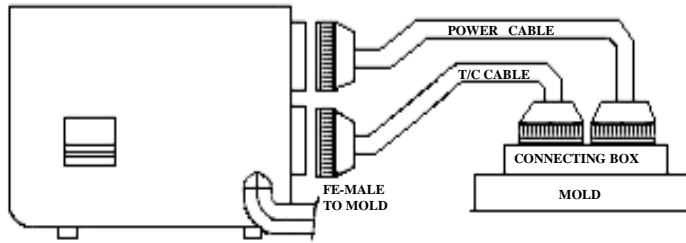

1) How to wire a heater and T/C in connectors

24 pins female standard connector 2-24 zones

5 pins female standard connection 1 zone

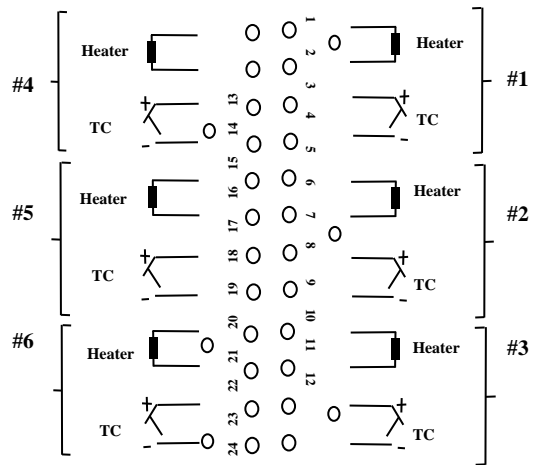
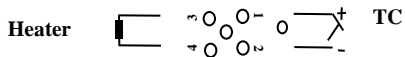

2) Standard specification

Female connector is attached to the mainframe, and YUDO supplies them with 5 pin, 16 pin and 24 pin as shown in the following standard.

NO.	CONTROLLER	CONNECTOR	QUANTITY
1	1 ZONE	5P Round Jack	1 Each
2	2Z	24P	1EA
3	3 - 4Z	24P	1EA
4	5 - 6Z	24P	1EA
5	7 - 8Z	24P	2EA
6	9 - 12Z	24P	2EA
7	13 - 16Z	24P	3EA
8	17 - 20Z	24P	4EA
9	21 - 24Z	24P	4EA

USER'S MANUAL

3) Options

For optional wiring requirements, separate power and T/C cables can be requested depending on customer's preference. But also the other connector not of YUDO standard could be equipped when those are supplied by customer. In this case, a cable is fabricated according to special order. Controller connector must be fabricated in accordance with the cable specification.

24P female connector

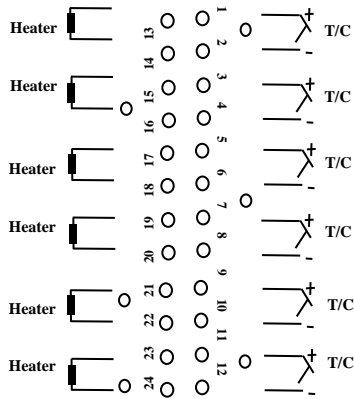

24P male connector

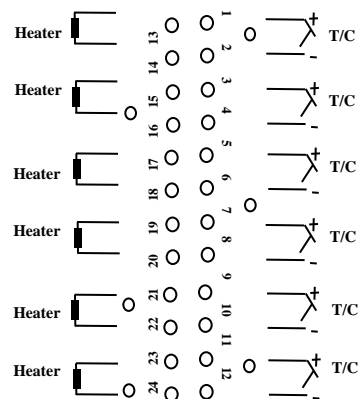

10、Diagram for Terminal Connection and Structure

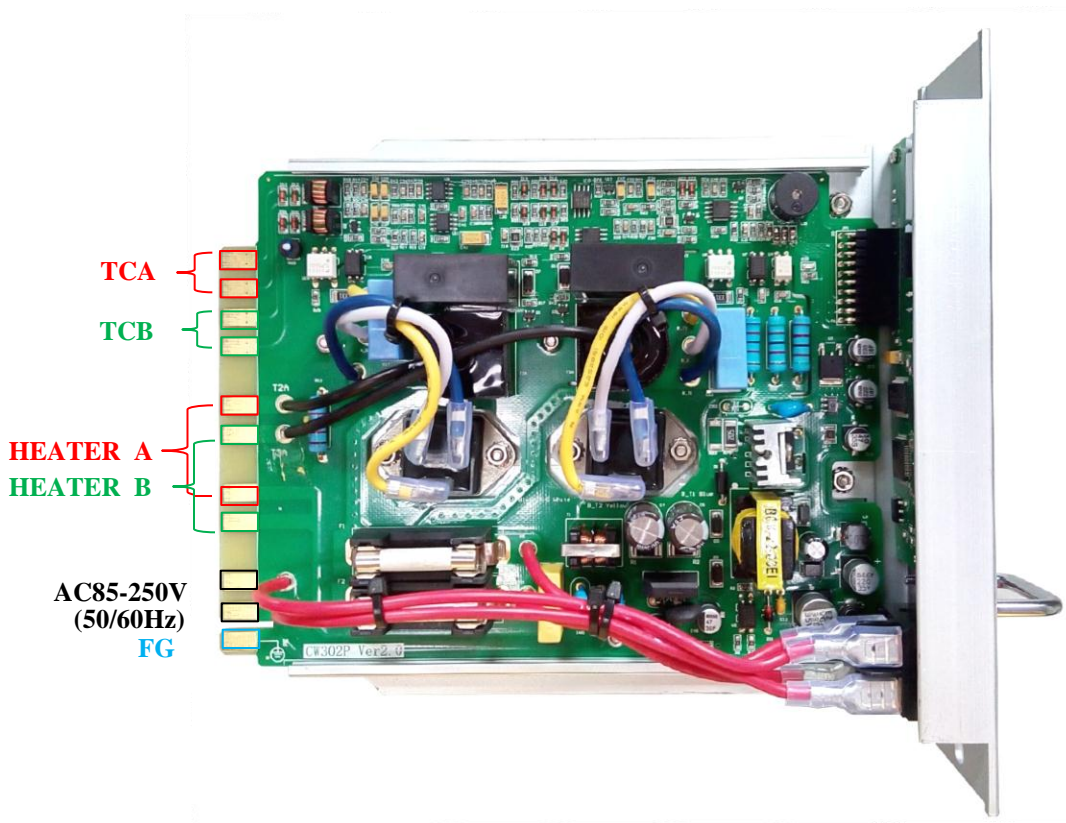

USER'S MANUAL

11、Electric Wiring Diagram

240V 3phase 3line type

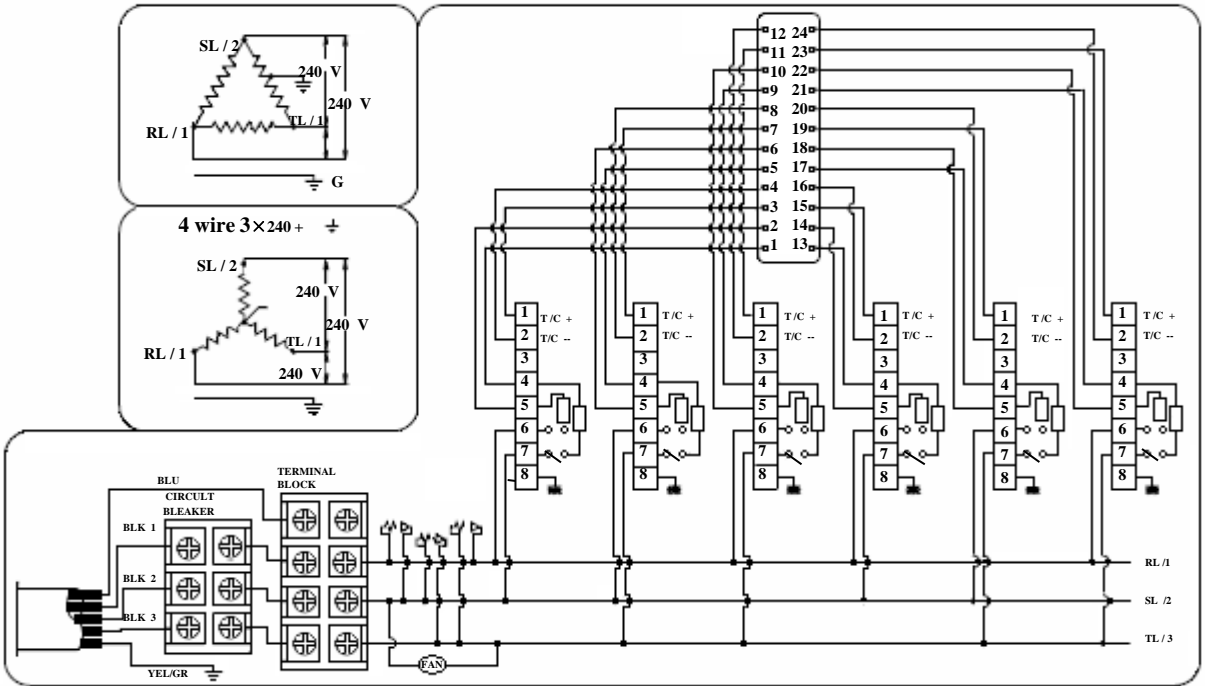

380 / 414V 3phase 4line type

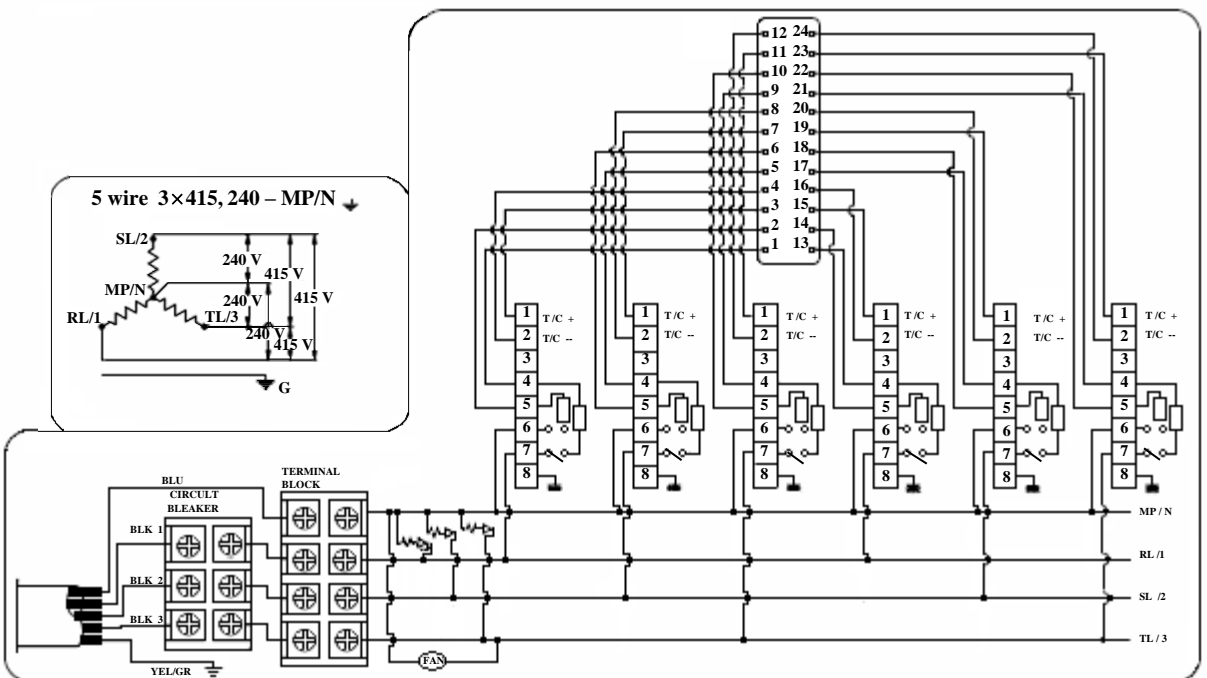

USER'S MANUAL

240V 1phase 2line type

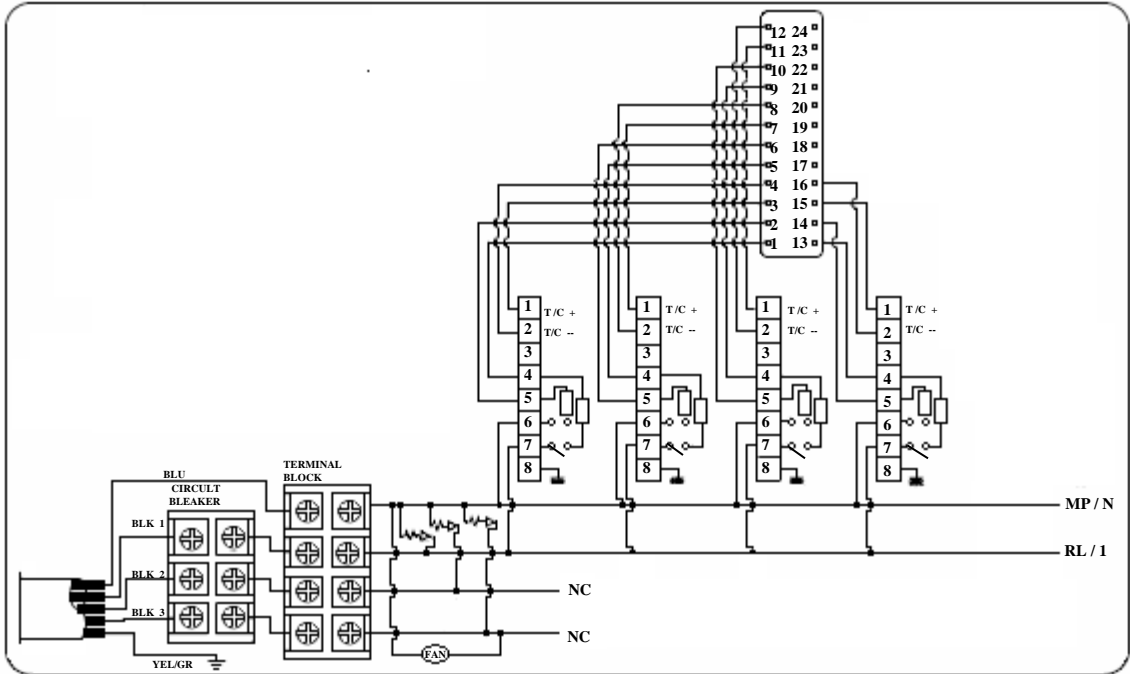

12. Wiring modification method

YUDO Temperature Controller operates with supply voltage 220-240AC . But even in case of supply voltage 380-415V AC 3phase 4 line. by re-wiring as shown below, 220-240V AC can be taken between one phase (R. S or D and Neutral (N)). Please check the right connection method . **Caution: Before re-wiring, make sure AC main power is turned OFF (SAFEST if power cable from Controller is disconnected from AC Main Power Supply) and Power Switch is turned OFF on controller.**

Re-wiring for supply voltage 220vAC from wiring for supply voltage 380V AC

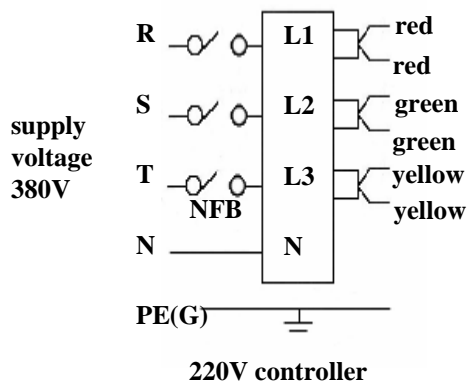
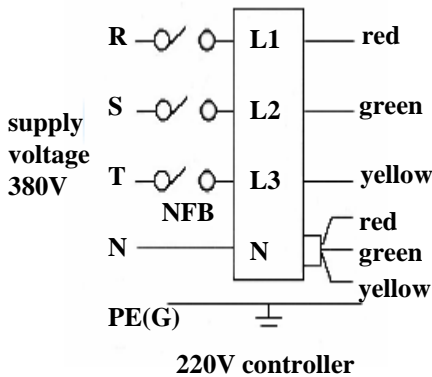

1. Power off.
2. Open the back cover of controller.
3. Separate all wires from N.
4. Plug black-sleeved RED wire into L1.
5. Plug black-sleeved GREEN wire into L2.
6. Plug black-sleeved YELLOW wire into L3.

## USER'S MANUAL

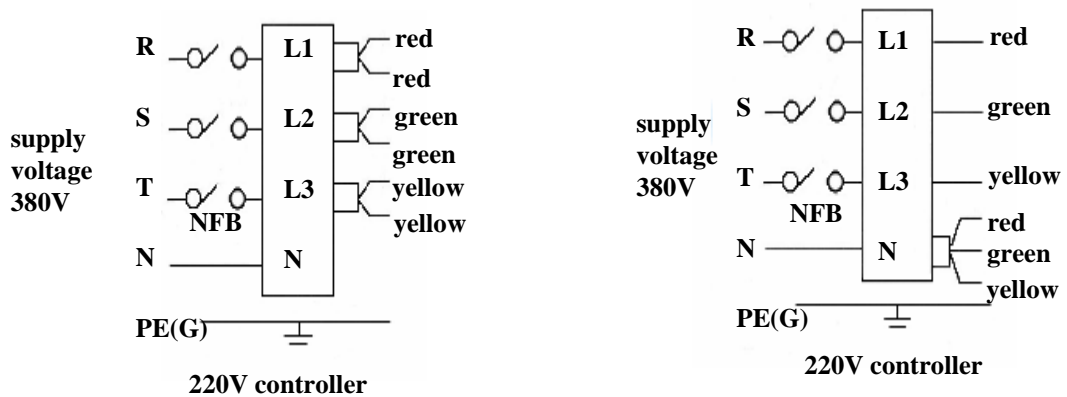
Re-wiring for supply voltage 380V AC from wiring for supply voltage 220V AC

1. Power off .
2. Open the back of controller.
3. Separate all 3 black-sleeved wires from L1,L2,L3.
4. Plug all 3 wires into N.

**Warning: Do not plug PE wire into N. Plugging PE wire into N may cause damage to controller, for which YUDO will not take responsibility.**

## 13、Default Value

## 1) Factory Defaults



NO.	Menu	Value
1	AL-H	50
2	AL-L	-50
3	HC-H	C16.0
4	HC-L	C 0.2
5	SOFT	T(time) 1 minute
6		A (output rate) 20%
7	STANDBY	T(time) 1 hour
8		P (rate) 50% (200°C)

## 2) User Settings Value

NO.	Menu	Value
1	SV (Setting Temp.)	200°C
2	IN (Sensor Type) J、K	J
3	C-F (Celsius/Fahrenheit)	C
4	UNIT (Temp. Unit)	0.1
5	HSCI (Output Mode)	PWM
6	TURN (Manual Tunning)	OFF
7	BUZZ (Alarm Setting)	ON
8	LOC	ON1
9	ID	0

## USER'S MANUAL

## 14、Security Marks

	<b>DANGEROUS VOLTAGE INSIDE</b>
	<b>DICONNECT AC BEFORE SERVICING</b>

## 15、Check Point for the Trouble Shooting

NO	Phenomenon	Cause	Check Point
1	tC.oP on PV	Sensor(T/C) open circuit	Check T/C wire with tester. When disconnected replace it.
2	tC.St on PV	Sensor(T/C) short circuit	Check if T/C wire is connected. Contacted if connector pressed by mold
3	tC.rE on PV	+/- polarity of T/C is reversed	Check connection and change polarity of T/C at connector affected to mold.
4	Ht.oP on PV	Heater open circuit	Check resistance of heater with tester, if it is blown out replace heater.
5	Ht.St on PV	1 Short circuit in heater 2 Capacity of heater is too high (15A or more)	Check short circuit of heater orf short in heater line with tester. Make wiring so that capacity of heater may lower than 15A.
6	tr.St on PV	TRIAC attached to heat radiation	Check pin in TRIAC. 2 or 3 pins may short circuit.
7	FU-1 on PV	F1 fuse is blown by over current	Replace F1 fuse(250V 15A)
8	FU-2 on PV	F2 fuse is blown by over current	Replace F2 fuse(250V 15A)
9	Temperature rises continuously	TRIAC attached to heat radiation borad of controller is damaged.	Check pin in TRIAC 2 or 3 pins maybe short circuit
10	Temperature drops continuously	1. F1 or F2 fuse blown out 2. Heater blown out 3. Heater wire disconnection 4. T/C wire disconnection	1. Change fuse 2. Check resistance of heater by tester 3. Check connection of heater 4. Check sensor disconnection
11	Setting temperature and real temperature deviates largely.	1. T/C contact is unstable 2. T/C type is different from setting	1. Check conctact state of sensor 2. Check sensor type
12	Temperature of controller is normal, but heater's temperature is too high.	T/C wire is pressed by mold or It's coating is peeled, so as to contact mold or line.	Check and replace T/C wire
13	Cotroller's setting temperature and real temperature are same ,but heater is too hot.	T/C sensor type between mold and controller is different. EX: CA(K)-- IC(J) IC(J)-- CA(K)	Make T/C (sensor) type of mold with that of controller.